



This manual is for reference and historical purposes, all rights reserved.

**This page is copyright© by M. Butkus, NJ.**

This page may not be sold or distributed without the expressed permission of the producer

I have no connection with any camera company

On-line camera manual library

This is the full text and images from the manual. This may take 3 full minutes for the PDF file to download.

**If you find this manual useful, how about a donation of \$3 to: M. Butkus, 29 Lake Ave., High Bridge, NJ 08829-1701 and send your e-mail address so I can thank you. Most other places would charge you \$7.50 for a electronic copy or \$18.00 for a hard to read Xerox copy.**

**This will allow me to continue to buy new manuals and pay their shipping costs.**

**It'll make you feel better, won't it?**

**If you use Pay Pal or wish to use your credit card,  
click on the secure site on my main page.**

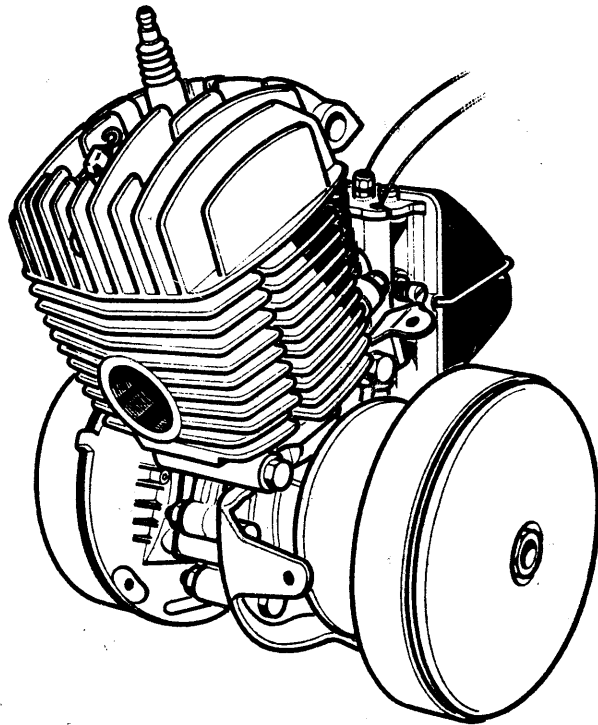

REPAIR OPERATIONS  
MODELS 40, 50, 7

*File  
From  
But Kos. 009*

## ALPHABETICAL INDEX

DESIGNATION	PAGES
Brakes (replacing the brake shoes)	68
Cables (replacing)	54,55
Carburetor (removing and refitting)	32,33
Carburetor (stripping and reassembling)	34,35
Center Stand (removing)	69
Chains (replacing)	69,70
Clutch (removing, refitting, replacing, reassembling)	45,46
Crankgear (removing, refitting, replacing crankgear bushings)	49,50
Cylinder Head - Cylinder (examination)	15,16
Engine (removing)	8,9
Engine (refitting)	10,11
Engine (disassembling)	12,13
Engine (reassembling)	17,18,19,20,21,22
Engine (decarbonizing)	23
Exhaust (removing, decarbonizing, and refitting)	24,25
Front and Rear Fenders (removing and refitting)	76,77
Flexible Bushings (replacing)	51,52,53
Flywheel Magneto (removing and refitting)	28,29
Fork (removing the main fork assembly)	59,60
Fork (refitting the main fork assembly, removing and refitting the fork complete)	61
Fork (replacing bushings and springs)	62
Frame (replacing)	56,57,58
Freewheel (replacing)	74
Handlebars (removing)	63
Ignition (checking timing)	26,27
Ignition (adjusting the ignition points and timing)	30,31
Matching (piston-cylinder)	14
Driven Pulley (removing and refitting)	47,48
Saddle (replacing)	69
Shock Absorbers (removing and refitting)	78,79
Steering Head (removing)	64
Steering Head (refitting)	65
Stroke Limiter (use)	7
Technical Specifications	1
Tools (special service)	2-6
Trouble Shooting Guide	80,81,82,83,84
Variator (description and operation)	36
Variator (components parts)	37
Variator (removing)	38,39
Variator (disassembling and reassembling)	40,41,42
Variator (adjusting and refitting)	43,44
Front and Rear Wheels (removing and refitting)	66,67
Front Wheels (replacing adjustment cones, cups, and bolts)	71,72
Rear Wheel (replacing ball bearings)	73,74
Wheels (check alignment)	75
Wiring Diagram 6 Volt	85
Wiring Diagram 12 Volt	86

## TABLE OF CONTENTS

DESIGNATION	PAGES
Technical Specifications	1
Tools (special service)	2-6
Use of the Stroke Limiter	7
Engine Removal	8,9
Refitting the Engine on the Frame	10,11
Disassembling the Engine	12,13
Piston Cylinder Matching	14
Examination of the Cylinder Head and Cylinder	15,16
Reassembling the Engine	17,17,19,20,21,22
Decarbonizing the Engine	23
Removing-Decarbonizing-Refitting the Exhaust	24,25
Testing Ignition Timing	26,27
Removing and Refitting the Flywheel Magneto	28,29
Adjusting the Ignition Points and Ignition Timing	30,31
Removing and Refitting the Carburetor	32,33
Disassembly and Reassembly of Carburetor	34,35
Description and Operation of the MOBYMATIC Variator	36
Variator (components parts)	37
Removing the Variator	38,39
Disassembly and Reassembly of Variator	40,41,42
Adjusting and Refitting the Variator	43,44
Removing-Refitting-Disassembling-Reassembling the Clutch	45,46
Removing and Refitting Driven Pulley	47,48
Removing and Refitting the Crankgear, Replacing Crankgear Bushings	49,50
Replacing Upper Engine Mounting Flexible Bushings	51,52,53
Replacing Cables	54,55
Replacing the Frame	56,57,58
Removing the Main Fork Assembly	59,60
Refitting the Main Fork Assembly, Removing and Refitting the Fork Complete	61
Replacing Fork Bushings and Springs	62
Removing the Handlebars	63
Removing the Steering Head	64
Refitting the Steering Head	65
Removing and Refitting the Front and Rear Wheels	66
Replacing the Brake Shoes	68
Removing the Center Stand, the Saddle, Replacing the Pedal Chain and the Engine Drive Chain	69,70
Replacing the Front Wheel Adjustment Cones, Cups, and Bolts	71,72
Replacing Rear Wheel Ball Bearings	73,74
Check Wheel Alignment	75
Removing and Refitting the Front and Rear Fenders	76,77
Removing and Refitting the Shock Absorbers and the Swing Arm	78,79
Trouble Shooting Guide	80,81,82,83,84
Wiring Diagram 6 Volt	85
Wiring Diagram 12 Volt	86

Free from  
Balkus.09

# TECHNICAL SPECIFICATIONS

<u>DIMENSIONS</u>	<u>MOTOBECANE 40 SERIES</u>	<u>MOTOBECANE 50, 50V SERIES</u>	<u>MOTOBECANE 7 SERIES</u>
Overall Length (inches)	66.19	69.34	63.40
Overall Width (inches)	24.82	24.82	24.82
Overall Height (inches)	39.00	39.79	38.80
Weight (pounds)	90 lbs.	103 lbs.	88 lbs.

## FRAME

Type: Pressed Steel

Suspension: Telescopic Front Fork	YES	YES	YES
Rear Suspension - Shock absorbers	NO	YES	NO

Brakes: Front and Rear Drum

Tires: Pressure Front 21 p.s.i.

Pressure Rear 26 p.s.i.

Fuel Capacity: (U.S. Gallon)	1	1	.8
------------------------------	---	---	----

Fuel Mixture: 4 oz. of high  
quality 2-cycle  
oil per gallon  
of gasoline

Miles Per Gallon:	143	143	143
-------------------	-----	-----	-----

## ENGINE

Type: Single cylinder, air-cooled, 2-cycle

Bore and Stroke: 1.53 X 1.64 inches

Compression Ratio: 7.8:1

Carburetor: Gurtner

Engine Displacement: 49cc

Ignition: Flywheel Magneto

## ELECTRICAL

Prior to January 1, 1978: 6 volt

After January 1, 1978: 12 volt

## VEHICLE IDENTIFICATION NUMBERS

Engine: Identification plate on engine cylinder head

Frame: Identification plate on front of frame

## PERFORMANCE

Maximum Speed: 20, 25, and 30 MPH

SPECIAL SERVICE TOOLS

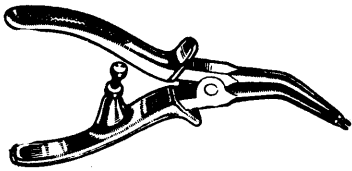

PART NO. 100001  
CIRCLIP PLIERS

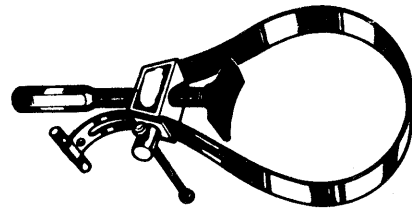

PART NO. 100005  
FLYWHEEL WRENCH

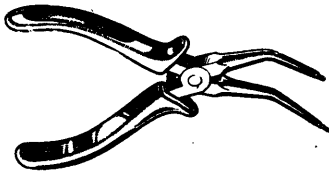

PART NO. 100002  
CIRCLIP PLIERS

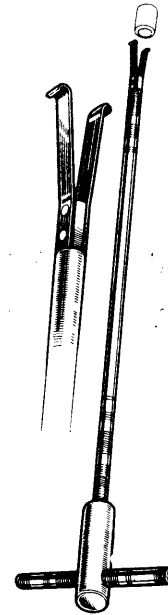

PART NO. 100006  
BUSHING EXTRACTOR

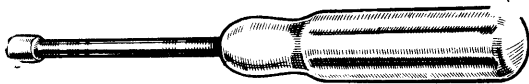

PART NO. 100003  
GREASE FITTING WRENCH



PART NO. 100004  
STROKE LIMITER

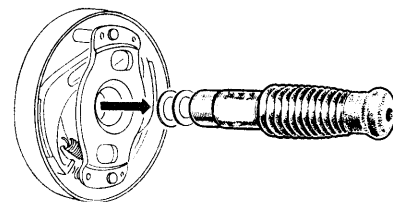

PART NO. 100007  
MAGNETIC EXTRACTOR

SPECIAL SERVICE TOOLS

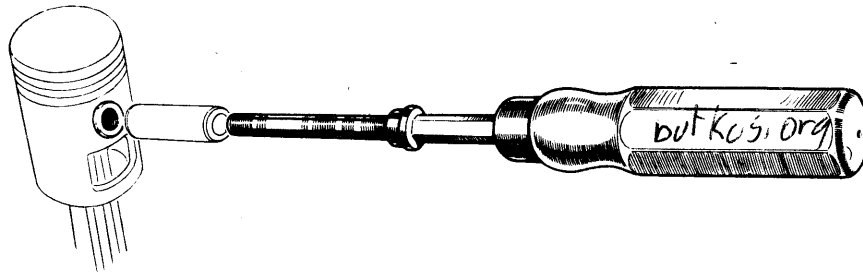

PART NO. 100008  
PISTON PIN TOOL

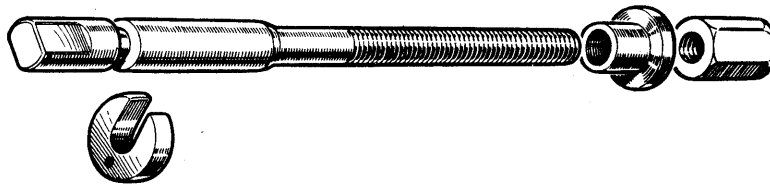

PART NO. 100009  
PEDAL BUSHING TOOL

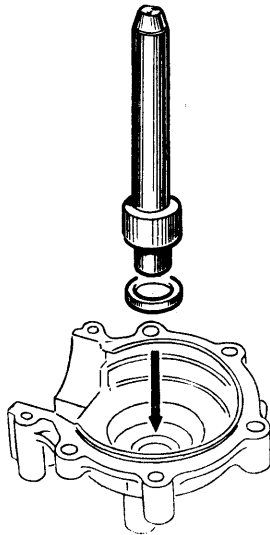

PART NO. 100010  
CRANKCASE SEAL TOOL

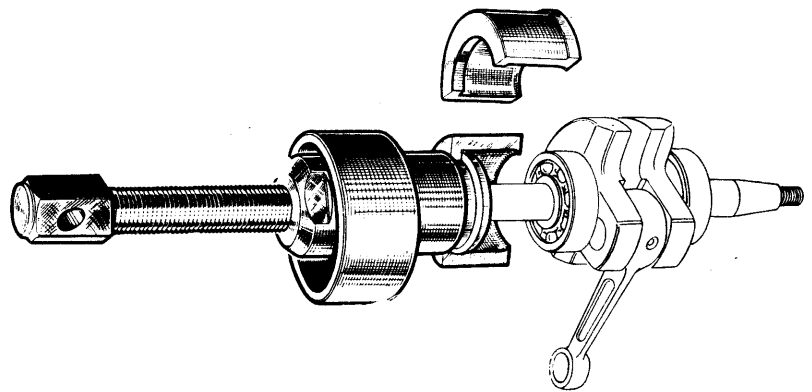

PART NO. 100011  
CRANKSHAFT BEARING PULLER

SPECIAL SERVICE TOOLS

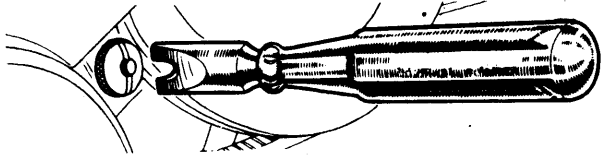

PART NO. 100012  
FORK TOOL

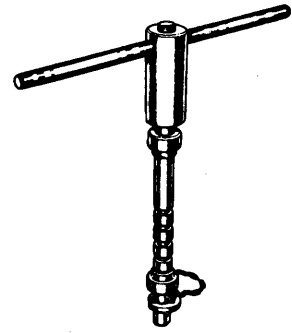

PART NO. 100016  
PRESS - STEERING HEAD RACES

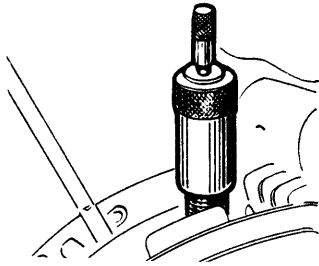

PART NO. 100013  
TIMING TOOL

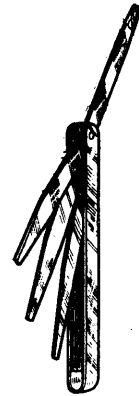

PART NO. 100017  
THICKNESS GAUGE - METRIC

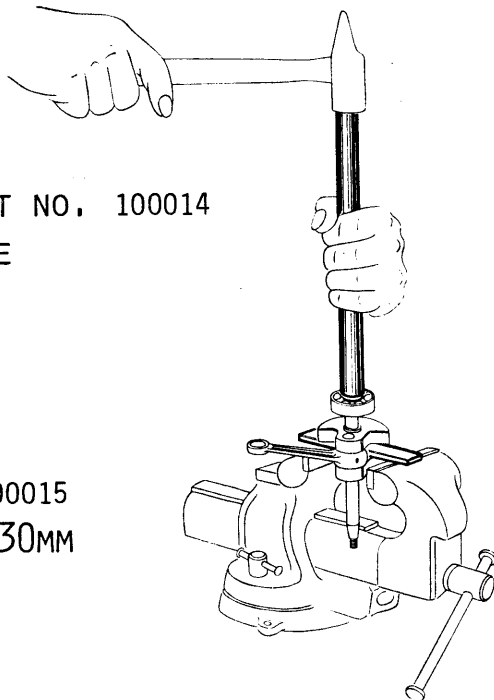

PART NO. 100014  
TUBE

PART NO. 100015  
BLADE 120x30MM

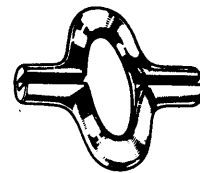

PART NO. 100018  
SPOKE WRENCH - 18



SPECIAL SERVICE TOOLS

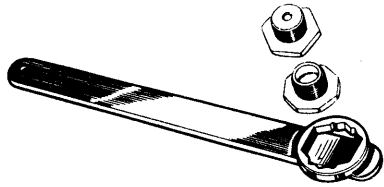

PART NO. 100019  
FORK PIVOT WRENCH

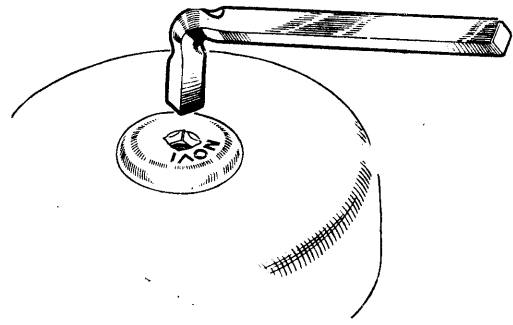

PART NO. 100023  
SQUARE DRIVE

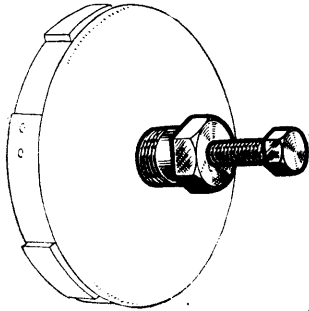

PART NO. 100020  
CLUTCH PULLER

*Free from Butkus.org*

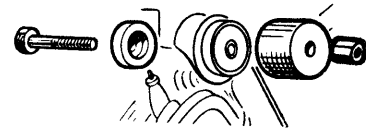

PART NO. 100024  
FLEXIBLOC EXTRACTOR AND  
INSTALLING TOOL

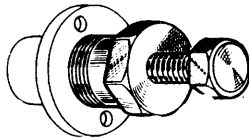

PART NO. 100021  
CAM PULLER

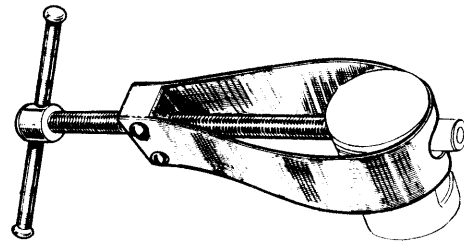

PART NO. 100025  
PISTON PIN EXTRACTOR

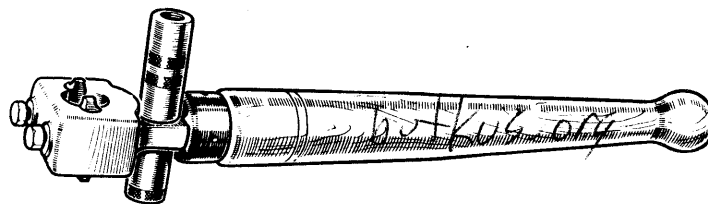

PART NO. 100022  
FREE WHEEL WRENCH

SPECIAL SERVICE TOOLS

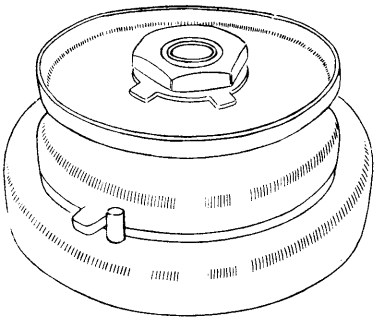

PART NO. 100026  
VARIATOR HOLDER

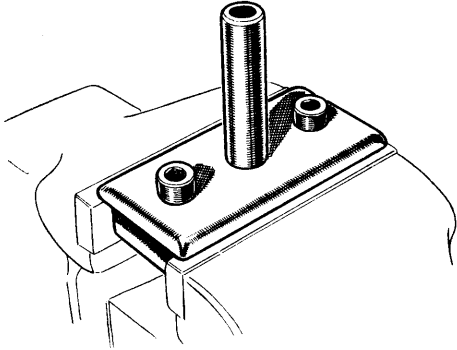

PART NO. 100027  
VARIATOR WRENCH

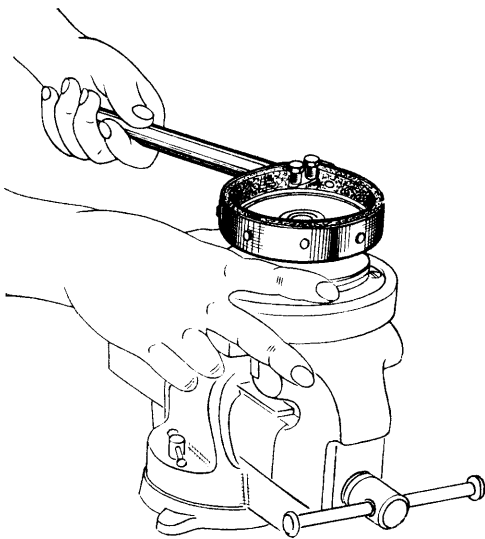

PART NO. 100028  
GREASE GUN

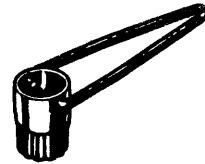

PART NO. 100029  
SPARK PLUG WRENCH

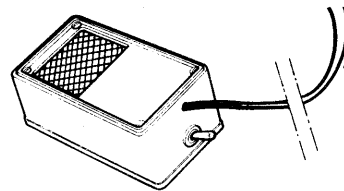

PART NO. 100031  
TIMING LIGHT

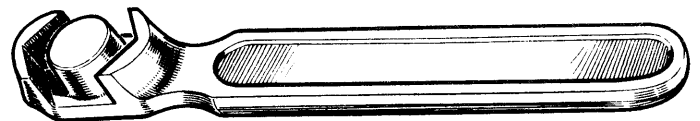

PART NO. 001229  
FORK WRENCH

## USE OF THE STROKE LIMITER

### I M P O R T A N T

For all types of engines to be serviced, the use of the stroke limiter, No. 100004, is required in most disassembly and reassembling operations.

This tool is designed to lock crankshaft revolution at mid-stroke and offers the advantage of leaving both hands free to perform the operations required.

DO NOT USE THE STROKE LIMITER ON ENGINES FITTED WITH FLAT-TOPPED PISTONS.

After having screwed the limiter into the whole threaded length of the spark plug hole, bring the piston to rest against it gently.

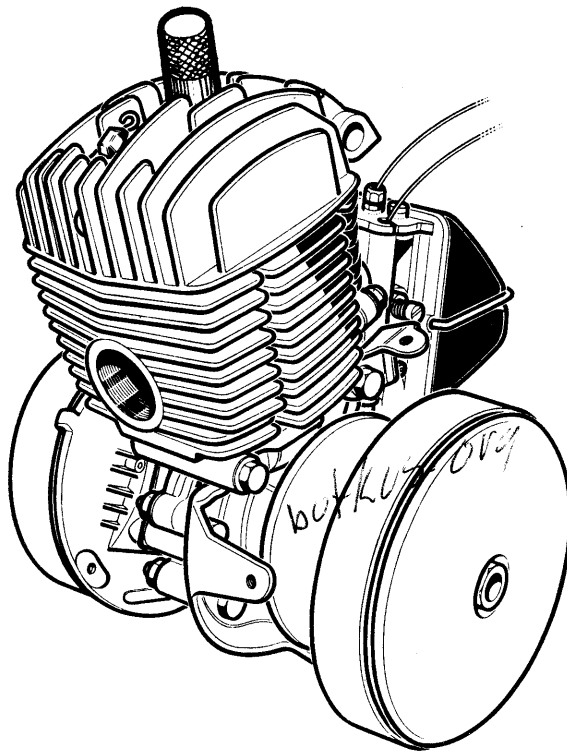

## ENGINE REMOVAL

- Remove both side covers (screwdriver).
- Disconnect the suppressor cap.
- Free the decompressor cable nipple using a screwdriver (fig. 1) and disconnect the cable.
- Loosen the nut securing the carburetor clamp (8mm socket) and remove the carburetor.
- Disconnect the wires at the terminals behind the flywheel magneto stator plate and slide them out of the guide spring.
- Disconnect the grey wire at the ignition coil and slide it out of the support bracket in the frame.
- Remove the belt from the pulley groove and pass it in front of the pedal (fig. 2).

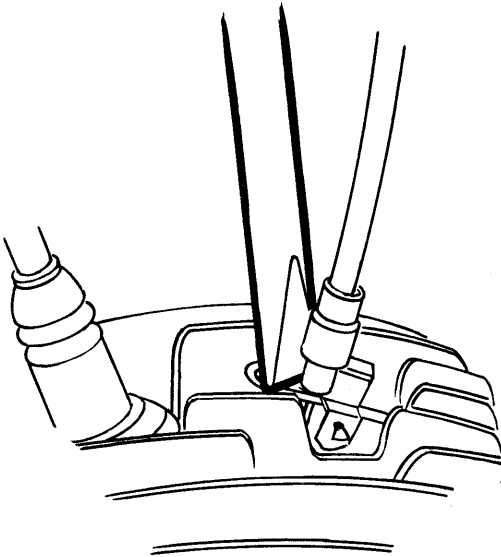

Fig. 1

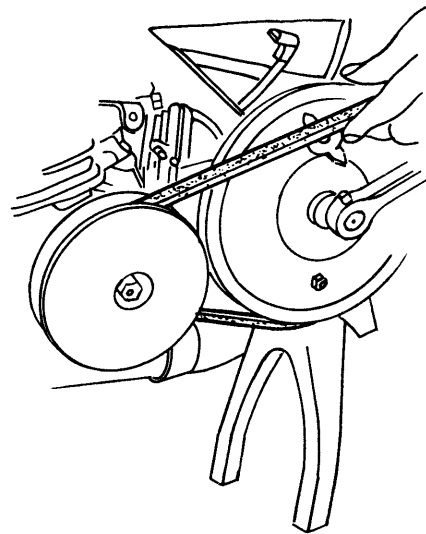

Fig. 2

## ENGINE REMOVAL CONT'D.

- Loosen the lower engine mounting nut and withdraw the bolt (10mm open wrench and socket).
- Loosen the self-locking nut of the upper engine mount (13mm wrench).
- Drive out the upper engine mounting axle only as far as the first spacer (fig. 3).
- Before removing the engine, carefully note the locations of the upper engine mount spacers.
- Tilt the engine and remove it (fig. 4).

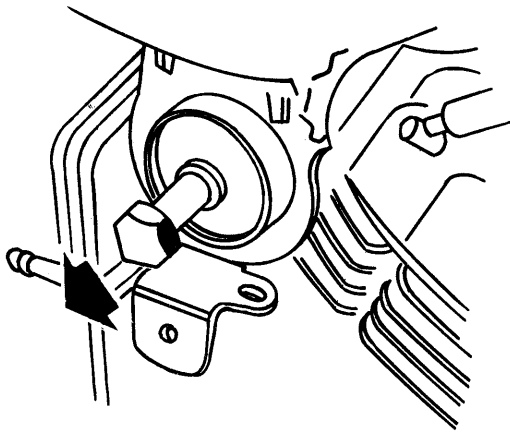

Fig. 3

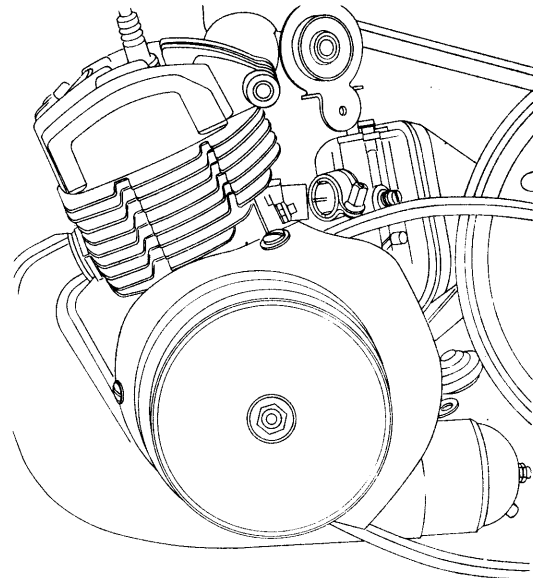

Fig. 4

## REFITTING THE ENGINE ON THE FRAME

- Inspect the upper engine mounting flexible bushings and insulation ring for good condition (fig. 1).
- Fit the engine through upper mounting bolt (operate as for removal).
- Check that spacers are correctly lined up and make sure to insert the eye ring of the ground lead between the spacer and cylinder head (R.H., fig 2).
- Tighten but do not lock upper engine mounting nut.
- Insert the screw into the lower engine mounting brackets and into the spacer which is fit in with the tension springs (fig. 3).

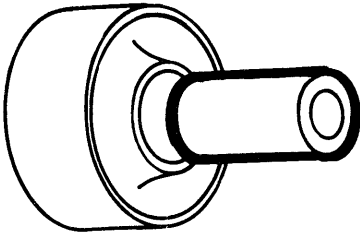

Fig. 1

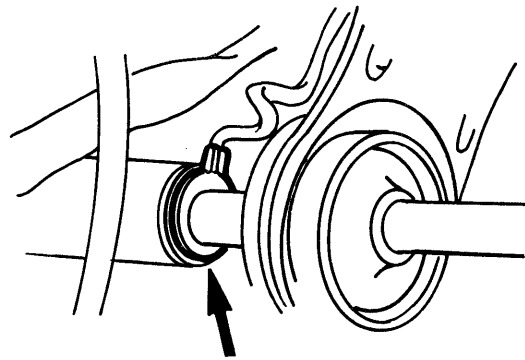

Fig. 2

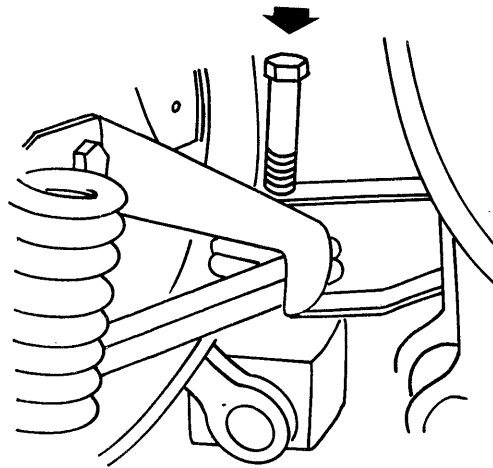

Fig. 3

## REFITTING THE ENGINE ON THE FRAME CONT'D.

- Tighten and lock lower engine mounting nut (10mm wrench).
- Refit the carburetor all the way onto the inlet pipe and lock the carburetor securing clamp nut (8mm socket).
- Reconnect the decompressor cable (screwdriver).
- Reconnect the wires to the spade connections behind the flywheel magneto stator plate (pass them through the guide spring, if equipped) (fig. 4).
- Slide the grey wire through the support bracket on the frame and reconnect it to the ignition coil (straight female terminal).
- Lock the upper engine mounting nut (while holding the other end of the bolt - 12mm wrench) after having installed the belt (fig. 5).

NOTE: Make certain to lock upper engine mounting nut after having installed the belt. Then the engine is in a medium swinging position, which will prevent the flexible bushings from sustaining damage.

- Refit the suppressor.
- Refit both side covers.

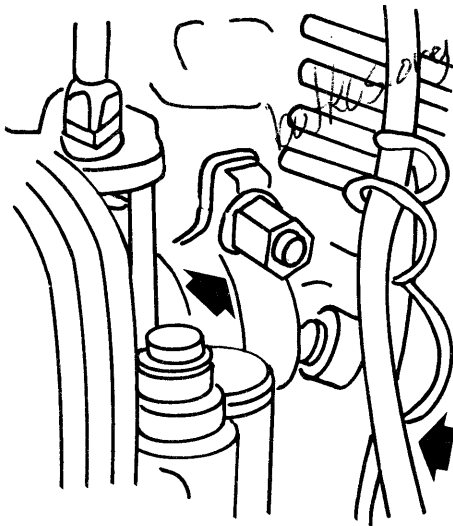

Fig. 4

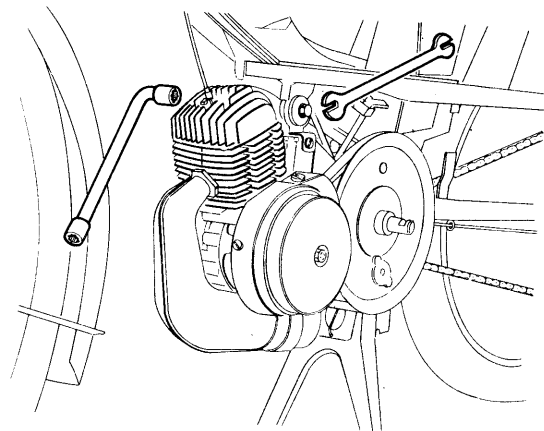

Fig. 5

## DISASSEMBLING THE ENGINE

- Engine removed.
- Remove the exhaust using 10mm and 11mm sockets to loosen exhaust clamp and a 32mm open wrench to loosen the nut connecting the exhaust to the cylinder.
- Set the engine in a vice by inserting a spacer between the lower engine mount plates so that the assembly may be firmly clamped (fig. 2).
- Remove belt cover using a screwdriver for variator engines or a 10mm socket for Dimoby clutch engines.
- Remove the flywheel magneto (See page 28).
- Remove the variator or the clutch assembly according to the type of machine serviced (See pages 38 and 43).
- Progressively loosen the cylinder head nuts at opposite corners.
- Remove the cylinder head and the gasket (10mm socket).
- Remove the cylinder and cylinder base gasket.

NOTE: After July, 1975, our engines are fitted with pistons having LEVELLED UP RINGS WHICH COVER THE LOCATING PINS (fig. 1).

- Withdraw the piston rings.
- Stuff a rag into the crankcase mouth and remove the wrist pin clips using flat nose pliers (fig. 2).
- Drive out the piston pin using the pin extractor tool, 100025, (fig. 3).

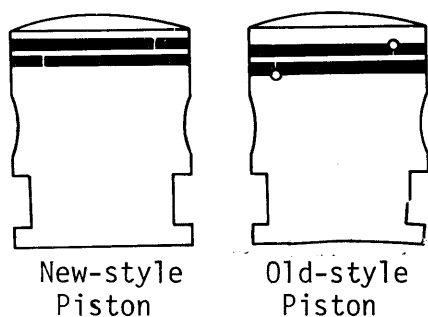

Fig. 1

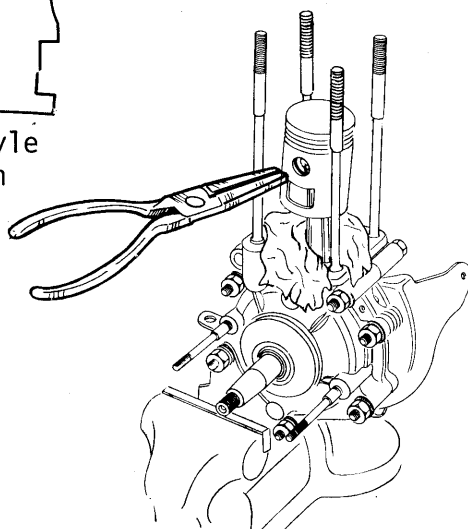

Fig. 2

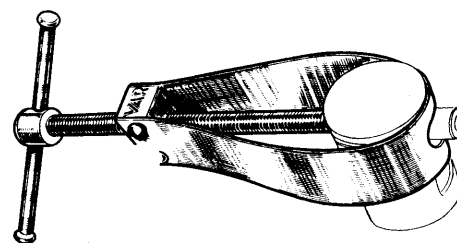

Fig. 3



DISASSEMBLING THE ENGINE  
CONT'D.

- Withdraw the needle cage from the con-rod small end.
- Loosen all crankcase retaining nuts.
- Remove the crankcase from the vice.
- Remove the crankcase retaining bolts and lower engine mounting studs (note the position of the studs and of the bracket for the belt guard).
- To prevent the crankshaft journal from overheating, insert the blade, 100015, on it. Repeat the operation for the other journal.
- Heat with a propane torch the crankcase half facing the clutch side around the outside of the crankshaft bearing (begin with this side because it is then easy to separate crankcase shells) (fig. 4).
- The crankcase half will drop away on its own (fig. 4).
- Repeat the operation for the other crankcase half (fig. 4).
- While the crankcase halves are hot, remove the oil seals with a screwdriver tapping from the outside to the inside of the crankcase half.
- Extract the crankshaft bearings using the crankshaft bearing puller, 100011 (fig. 5).
- Note the arrangement of shims behind the crankshaft support bearing if the crankshaft is so fitted.

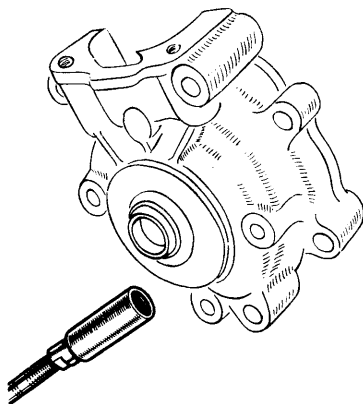

Fig. 4

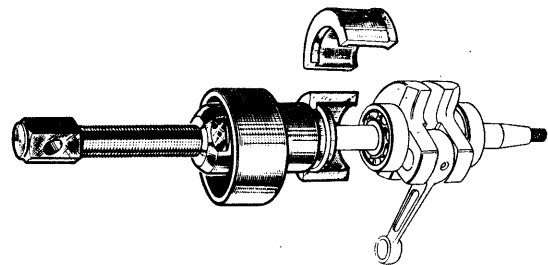
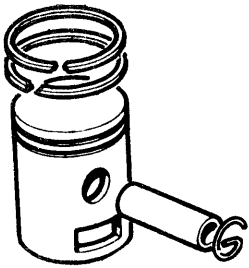

Fig. 5

# PISTON CYLINDER MATCHING

The spare part numbers listed below concern pistons fitted with levelled-up rings that are mounted in lieu of former pistons (series 16853 to 16859).



22273	-----	W
22274	-----	AA
22275	-----	A
22276	-----	C
22277	-----	E
22278	-----	G
22279	-----	J
22280	-----	L
22281	-----	N
22435	-----	P

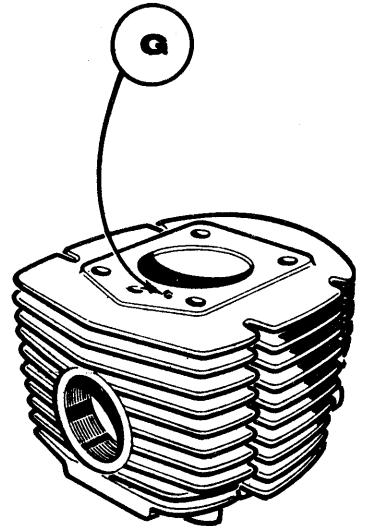

## EXAMINATION OF THE CYLINDER HEAD AND CYLINDER

### Examination of the Cylinder Head:

- Check that the cylinder head bottom base is flat (grind it with a surface plate if necessary).
- Refit the spark plug and check the decompressor valve for leakage by pouring fuel in the combustion chamber (fig. 1).
- Except in case of absolute necessity, the decompressor valve should not be removed from the cylinder head assembly.
- In case of leakage and if the valve is not worn out, tap the valve head gently to seat.

### Examination of the Cylinder:

- Make sure that the cylinder wall is neither scuffed nor scored (lack of chromium plated surface).
- Measure the piston clearance (difference between the minimum cylinder bore and the maximum piston diameter), the piston ring end gap (fig. 2) and the clearance between ring and groove.

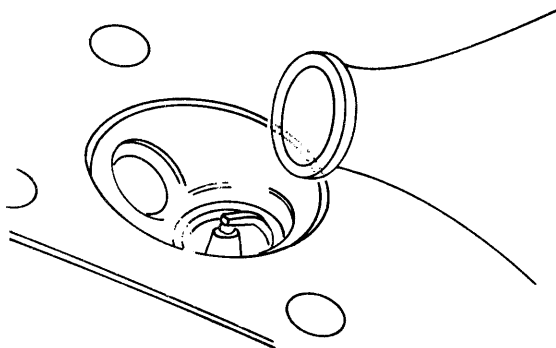

Fig. 1

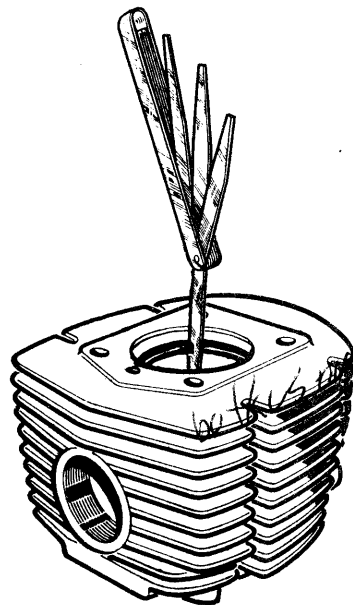

Fig. 2

EXAMINATION OF THE CYLINDER HEAD AND CYLINDER  
CONT'D.

- If installing a new piston, refer to the matching list on page 14.

CLEARANCES IN MM		STANDARD	MAXIMUM
Piston Clearance (skirt)		0.005 to 0.010	0.050
Ring end gap	top ring second ring	0.10 0.10 + 0.10	0.40
Ring groove Side gap	top ring second ring	0.03 to 0.060	0.15

- Fit the small end needle cage and insert the wrist pin in it (fig. 3).
- The pin should turn freely without vertical play.

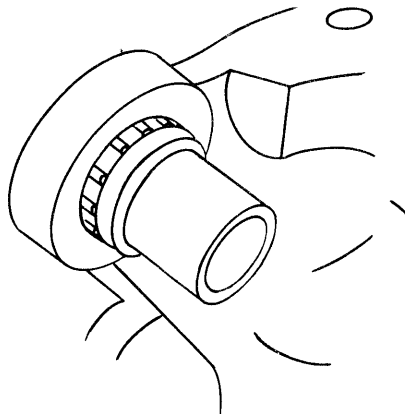

Fig. 3

## REASSEMBLING THE ENGINE

NEVER INSTALL USED GASKETS; ALWAYS USE NEW ONES.

- When fitting a new engine crankcase or a new crankshaft, the side play should be adjusted.

### SIDE PLAY ADJUSTMENT:

To effect this operation, you need two dummy bearings that you can make yourself.

Use emery cloth on the inner and outer races of two new bearings (diam. 16 X 42 X 13 - No. 16906) until the bearings can rotate freely on the crankshaft journals and the crankcase shell housings. This operation must be done without crankcase seals:

- Place the dummy bearings on the crankshaft tapered ends.
- Place this assembly into the crankcase.
- Fit the crankcase paper gasket.

NOTE: From January 1, 1976, the paper gasket sealing the crankcase halves has been substituted by a special sealing compound. Nevertheless, when servicing an engine, we recommend cleaning thoroughly the mating surfaces and fitting a paper gasket.

- Place this assembly in a vice (over lower lugs and crankcase upper screws).
- Roughly assess the existing side play with a depth caliper gauge.
- Disjoint crankcase halves and place washers between the two crankshaft balance weights and bearings in order to balance the con-rod between the shells.

SIDE PLAY = 1/10MM

## REASSEMBLING THE ENGINE CONT'D.

### CRANKSHAFT FINAL ASSEMBLY:

- Insert a steel blade (length - 120 X 30 X 7mm - No. 100005) between crankshaft balance weights (fig. 1).
- Install the assembly (without squeezing) in the jaws of a vice opened at approximately 75mm (fig. 1).
- If shims were fitted to the end of crankshaft refit them.
- Install the bearing on crankshaft journal.

NOTE THE DIRECTION in which the bearings are facing. The rounded chamfered side must face the crankshaft balance weight (fig. 2).

- Drive the bearing home against the counterweight with a tube (diam. 18 X 22 X 150mm - No. 100014, fig. 1).
- Proceed likewise for the other crankshaft end.

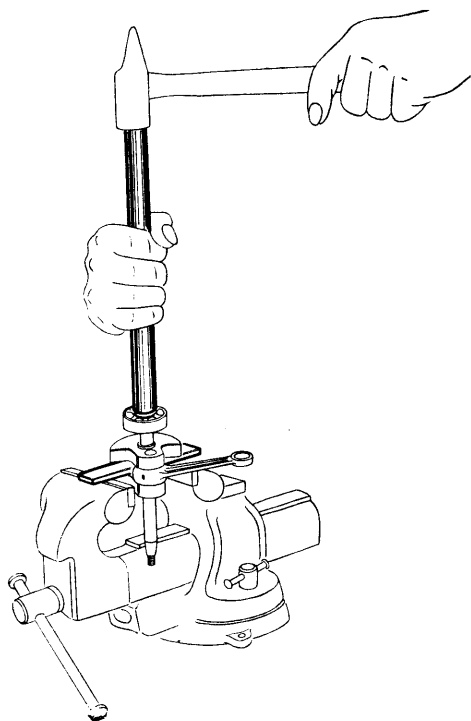

Fig. 1

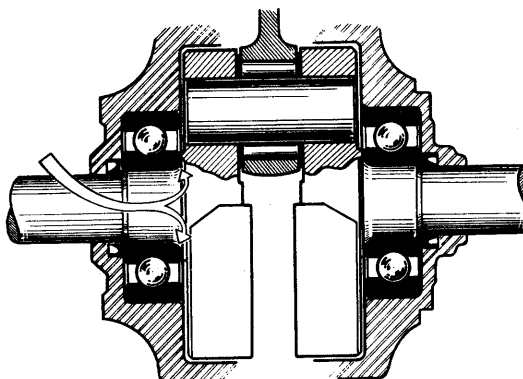

Fig. 2

REASSEMBLING THE ENGINE  
CONT'D.

REASSEMBLING THE CRANKCASE:

- Oil the crankshaft tapered ends, the bearings, and the bearing cages.
- Heat moderately the shell (facing the flywheel magneto) around the bearing housing until smoke appears.
- Fit a new oil seal with the crankcase seal fitting tool, No. 100010, fig. 3.

NOTE: Seals must be fitted with the spring and lips facing outwards.

- Very quickly fit the crankshaft assembly (flywheel magneto side) in the crankcase half; the bearing will locate itself correctly.
- Fit the oiled paper gasket to the crankcase half (see NOTE on page 17).
- Repeat the operation for the other crankcase half.
- Tighten but do not lock the two upper screws after having mounted the lug for securing the belt cover (variator engines) (fig. 4).
- Clamp (moderately) the engine in a vice over the crankcase lower bosses.
- Make sure the cylinder-crankcase mating surfaces are completely free from distortion; if necessary, tap on the upper part of a stud (assembling cylinder and cylinder head) with a mallet.
- Trim the paper gasket with a scraper.

NOTE: As far as variator engines are concerned, we recommend the positioning of the belt cover upper mounting lug before locking the crankcase half upper mounting screw. The top of this mounting lug will rest against the cylinder's lowest radiation fins (fig. 4).

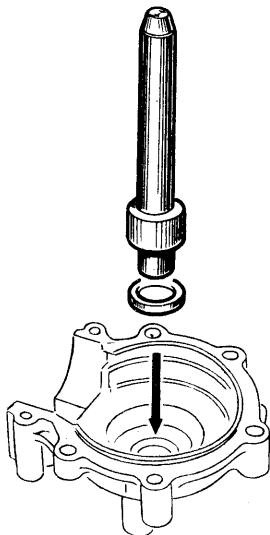

Fig. 3

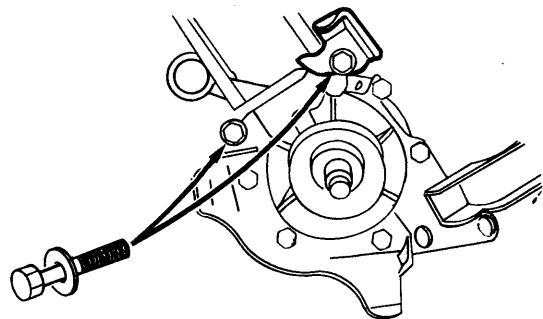

Fig. 4

## REASSEMBLING THE ENGINE

CONT'D.

- Lock the two upper mounting screws.
- Fit the lower engine mounting brackets and the dual lug securing the belt cover (variator engines).
- Fit and lock the crankcase mounting nuts (nuts on flywheel magneto side) with a 10mm wrench.
- Place a spacer between the lower engine mounting brackets to hold the engine firmly in the vice (fig. 5).
- Rotate the crankshaft. If it does not rotate freely, slightly tap on the crankcase shell (clutch side and variator side) with an aluminum mallet to position the bearing.

### REASSEMBLING THE PISTON:

- Smear the needle cage with oil and insert it in con-rod small end.
- Position the piston over the con-rod in such a way that the ring groove pegs face the exhaust port.
- Insert the dummy wrist pin which comes with Tool No. 100008 to align the assembly (fig. 6).

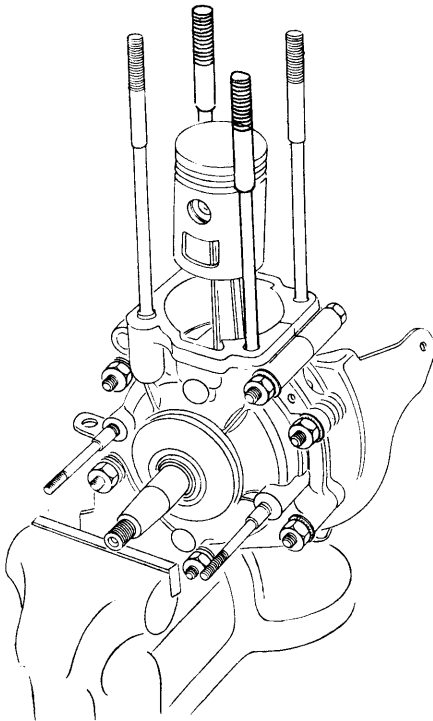

Fig. 5

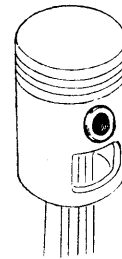

Fig. 6



REASSEMBLING THE ENGINE  
CONT'D.

- Fit the replacement wrist pin using piston pin assembler No. 100008.
- Heat (moderately) the piston dome (torch) until smoke appears. (This is not necessary for a new wrist pin that is an easy sliding fit.)
- Insert the assembler tip into the wrist pin (fig. 7).
- Push home while pressing against the opposite side of the piston to prevent unnecessary pressure on the big-end bearing. The assembler stop will correctly position the pin in the piston (fig. 7).
- Place the cylinder on the heated piston without the rings or piston pin clips installed. The cylinder will slide down as the temperature evens out. This operation prevents piston distortion while cooling (fig. 8).
- When the piston/cylinder assembly has cooled off, check con-rod alignment.

CHECKING ROD ALIGNMENT:

- Secure the cylinder with two washers and two opposite cylinder head nuts. Bring the piston to T.D.C.
- Slide in a tapered 0.07mm feeler gauge between the piston (at pin holes) and cylinder.
- If the gauge slides freely through one side and not through the other, the rod proves to be out of alignment. Remove the cylinder and proceed with straightening.

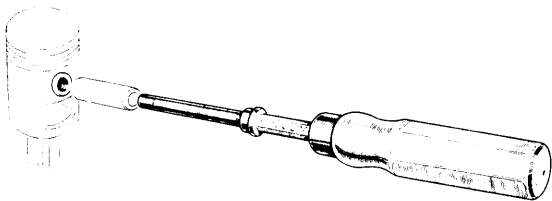

Fig. 7

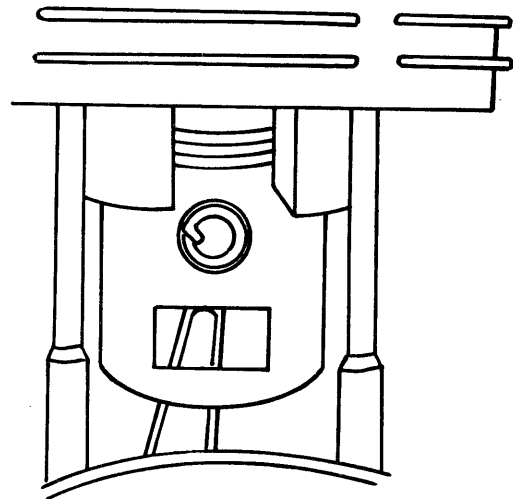

Fig. 8

REASSEMBLING THE ENGINE  
CONT'D.

STRAIGHTENING CONNECTING ROD:

- Clamp the crankcase in the vice and insert a bar through piston pin as shown in figure 9.
- To straighten the rod, apply force to the bar.
- Check rod alignment and straighten again until the piston is correctly centered in the cylinder.
- Fit new wrist pin lock rings using flat nose pliers.
- Smear the piston rings with oil and fit them on the piston.

REASSEMBLING CYLINDER - CYLINDER HEAD:

- Bring the piston to T.D.C. and make certain that the piston rings seat firmly in grooves.
- Fit the oiled gasket on the base of the cylinder.
- Place the cylinder on the mounting studs, smear the bore with oil and lower gently.
- Fit the new cylinder head gasket.
- Fit the cylinder head making sure its bottom base is perfectly clean.
- Fit washers on the studs and tighten progressively the nuts at opposite corners to 9 ft. lbs.
- Install the variator or clutch (See page 43).

Fig. 9

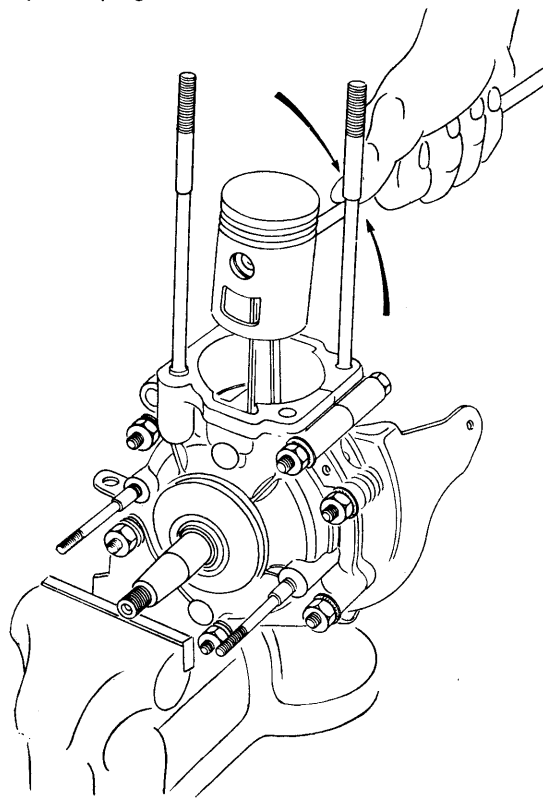

## DECARBONIZING THE ENGINE

- Remove the exhaust (See page 24).
- Remove left and right hand covers.
- Remove the suppressor cap.
- Disconnect the decompressor cable using a screwdriver.
- Loosen but do not remove cylinder head nuts.
- Loosen the upper engine mounting nut.
- Drive out the upper engine mounting axle as far as the first spacer only.
- Tilt the engine and remove it from the axle.
- Disconnect the wires at the terminals behind the flywheel magneto stator plate and slide them through the guide spring.
- Place a block under the engine to prevent the lower mounting flexible bushing from being damaged.
- Remove the cylinder head nuts using a 10mm socket.
- Remove the cylinder head and the gasket.

NEVER USE HARDENED TOOLS THAT WILL SCRATCH OR NICK THE COMBUSTION CHAMBER AND PISTON DOME.

- Bring piston to T.D.C.
- Scrape the carbon deposits from the exhaust port (fig. 1).
- Always fit a new cylinder, head, and exhaust gasket.

REASSEMBLING AND REINSTALLING THE ENGINE:

See pages 8, 9, 15, 16, 22.

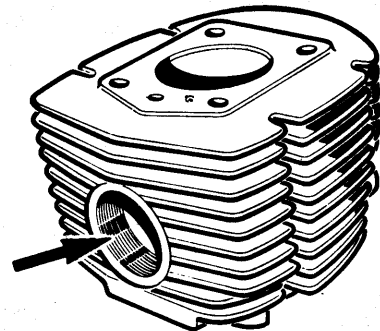

Fig. 1

## REMOVING, DECARBONIZING, REFITTING THE EXHAUST

### REMOVING THE EXHAUST PIPE (Blunderbuss type - Fig. 1)

- Loosen the nut (10mm and 11mm wrenches) and remove the exhaust clamp nut, but do not remove the spacer between the engine mountings (fig. 2).
- Loosen the nut (32mm wrench) threaded into the cylinder and remove the exhaust completely (fig. 3).

### DECARBONIZING:

- Loosen the locknut and the nut securing the exhaust tail cap.
- Remove the baffle plate and the tail cap.
- Clean out the holes in the inner baffle plate and tail pipes (fig. 4).
- Scrape out the exhaust pipe entry.

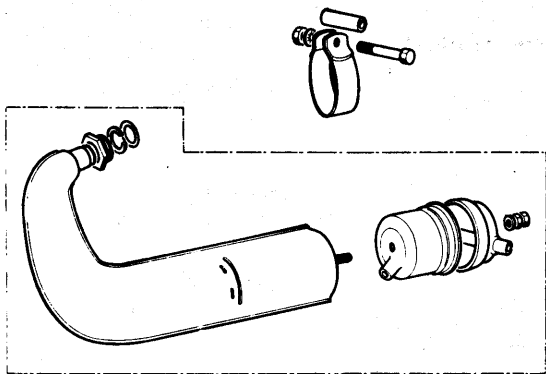

Fig. 1

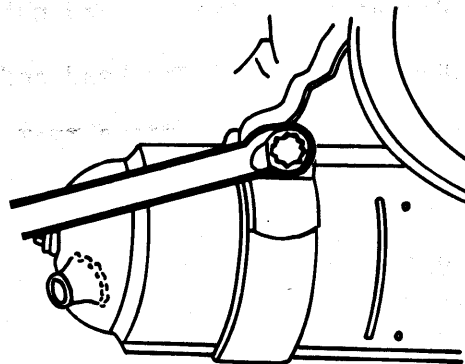

Fig. 2

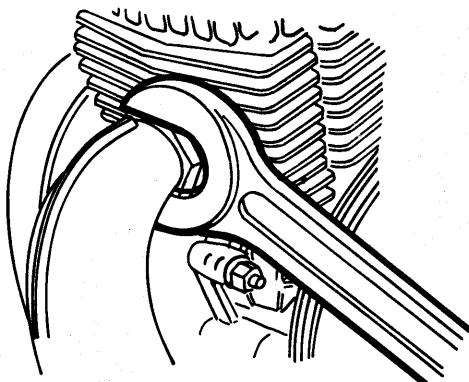

Fig. 3

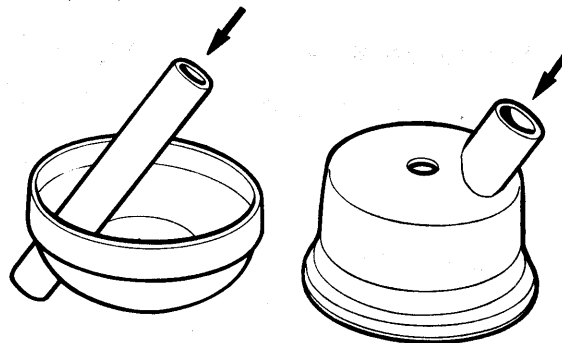

Fig. 4

## REMOVING, DECARBONIZING, REFITTING THE EXHAUST CONT'D.

### REMOVING THE EXHAUST PIPE (Oval type with crossed chambers, Fig. 5)

- Remove the two bolts on the exhaust clamp using a 10mm socket.
- Loosen the nut connecting the exhaust to the cylinder (32mm wrench) and remove the exhaust completely.

### DECARBONIZING:

- Loosen the nut on the clamp securing the muffler to the pipe (10mm wrench).
- Remove the muffler.
- Insert a triangular scraper through the hole and scrape all carbon deposits from around the edges as shown in figure 6.
- Insert a steel cable (diam. 7mm - length: 250mm) into the tail pipe and clean it out.
- Lastly, shake the exhaust vertically to remove deposits from the entry hole.

### REFITTING:

- Reverse the procedure and fit a new sealing washer in the exhaust port of the cylinder.

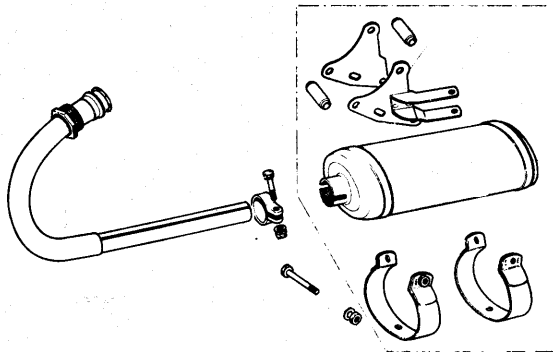
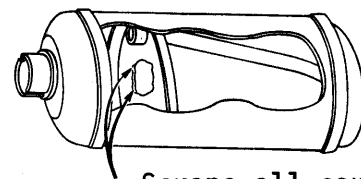

Fig. 5



Insert a steel cable (diam. 7mm) into the tail pipe.

Scrape all carbon deposits with a scraper.

Fig. 6

## TESTING IGNITION TIMING (WITHOUT REMOVING THE ROTOR)

- Remove right hand side cover.
- Disconnect the grey wire from the ignition coil (fig. 1).
- Attach one probe from the ohm meter to the grey wire (fig. 4)
- Attach the other ohm meter lead to a ground point. (Example: Cylinder head) (fig. 4)
- Disconnect the black wire (lighting system) from the straight female 6.35mm terminal at the stator plate.
- Remove the radio suppressor and spark plug.
  1. Screw in the timing tool (No. 100013) in place of spark plug (fig. 2).
  2. Bring piston to T.D.C by rotating the rotor in the normal running direction.

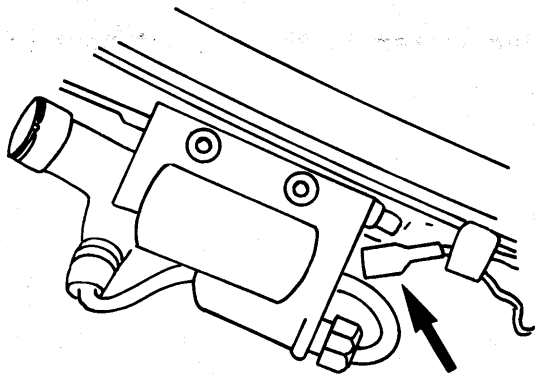

Fig. 1

NOTE: When testing and resetting the ignition timing on the machine with a 12 volt lighting system (manufactured after January 1, 1978), a timing light tester, Part No. 100031, must be used. An ohm meter will not register an accurate reading.

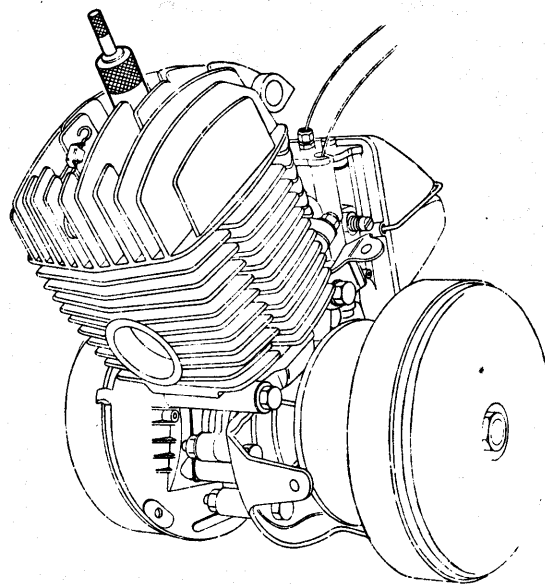

Fig. 2

TESTING IGNITION TIMING  
(WITHOUT REMOVING THE ROTOR)  
CONT'D.

3. Turn the timing tool until the top edge of the tool is aligned with the lower edge of the blue stripe (fig. 3).
4. Rotate the rotor clockwise one full revolution and as the blue stripe just begins to appear, the ohm meter should deflect to  $\infty$ . Points just begin to open. If a timing lite/tester is used, the light will go "ON" (fig. 4). (See note, page 26.)

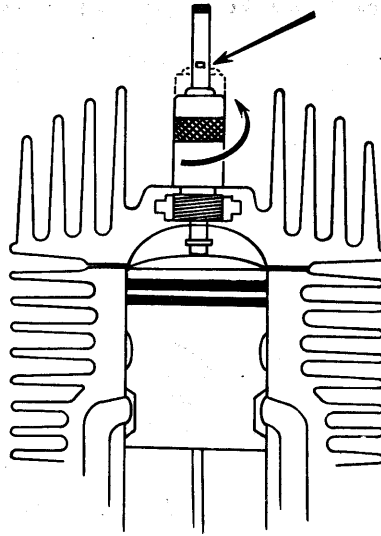

Fig. 3

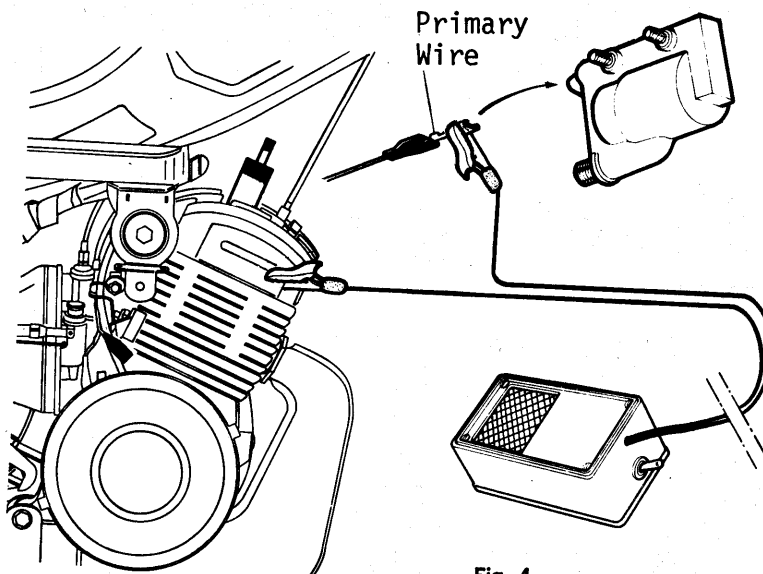

Fig. 4

## REMOVING AND REFITTING THE FLYWHEEL MAGNETO

### REMOVAL:

- Remove the right hand side cover.
- Remove the flywheel magneto cover.
- Remove the radio suppressor and spark plug. Disconnect the wires from the terminals behind the flywheel magneto stator plate and the grey wire from the ignition coil.
- Attach the flywheel wrench to the rotor (Tool No. 100005).
- Loosen the rotor nut (left hand thread) using the square drive wrench, 100023, (fig. 1).
- Remove the rotor.

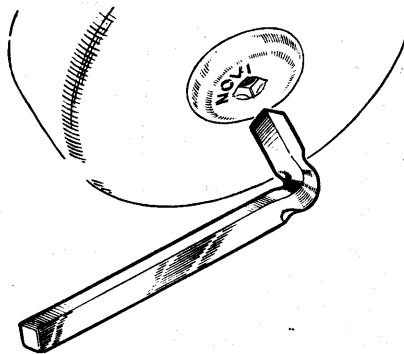

Fig. 1



## REMOVING AND REFITTING THE FLYWHEEL MAGNETO CONT'D.

- Screw the cam puller, No. 100021, onto the cam.
- Slowly screw in the center screw of the puller and pull the cam off the crankshaft end (fig. 2).
- Remove the stator plate self retaining nuts (8mm wrench) and remove the conical spring washers (fig. 2).
- Remove the stator plate, the paper gasket and the rubber gasket (fig. 3).

### REFITTING:

- Fit the paper gasket and rubber gasket.
- After testing or stator plate replacement, position the stator on the two studs. Drive fully home on crankcase.
- Fit the four conical spring washers and the two self retaining nuts.
- Screw on gradually and lock the self retaining nuts (8mm wrench) (fig. 2).
- Adjust ignition timing and breaker point gap as described on the following page.

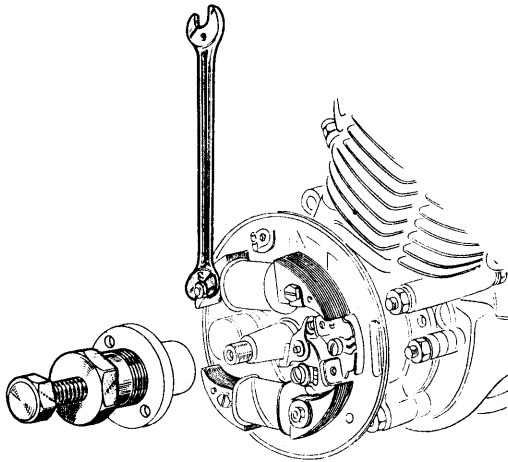

Fig. 2

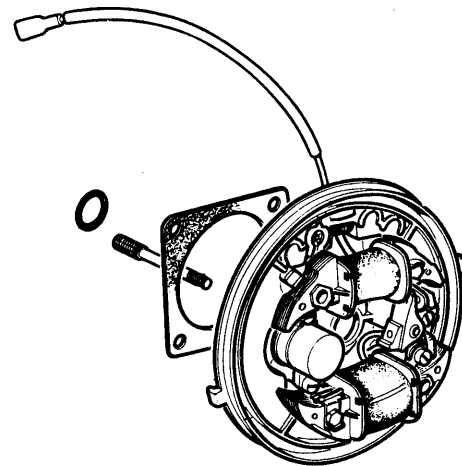

Fig. 3

## ADJUSTING THE CONTACT BREAKER AND IGNITION TIMING

### ADJUSTMENT OF THE BREAKER POINT GAP:

- Temporarily install the cam on crankshaft end and rotate it gently to obtain maximum gap between contact points (fig. 1).
- Adjust the gap with the feeler gauge (No. 100017, fig. 2) to between 35/100mm minimum and 40/100mm maximum.

### IF NECESSARY PROCEED AS FOLLOWS:

- Loosen the retaining screw of the fixed arm using a screwdriver (fig. 2).
- Pivot the breaker assembly to adjust to the specified gap (fig. 2).
- Tighten the fixed arm retaining screw.
- Check the maximum point gap after tightening the fixed arm retaining screw.

### SETTING THE IGNITION TIMING:

- Remove spark plug and install timing tool.
- Bring the piston to top dead center.
- Turn the timing tool until the top edge of the body of the tool is aligned with the lower edge of the blue stripe.
- Rotate the engine counterclockwise (viewed from the magneto side) until the blue stripe just disappears.
- Disconnect the grey wire from the H. T. coil, and attach one probe from the ohm meter to the grey wire.

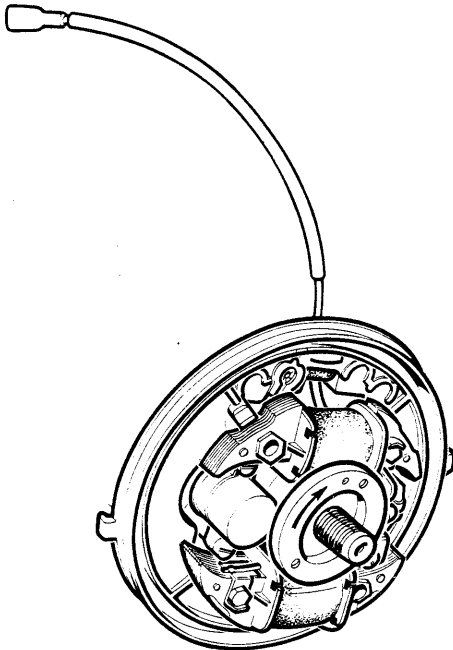

Fig. 1

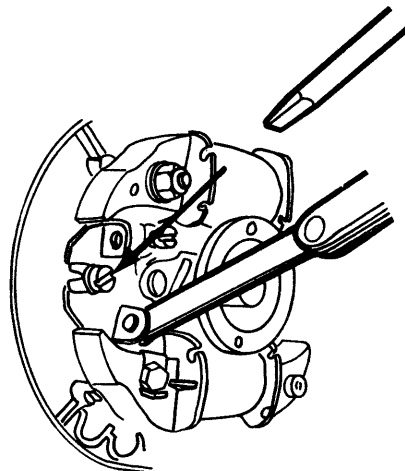

Fig. 2

ADJUSTING THE CONTACT BREAKER AND IGNITION TIMING  
CONT'D.

IMPORTANT: See Note, Page 26.

- Attach the other ohm meter probe to ground (at the cylinder head).
- Disconnect the black wire from the stator plate plug (on the magneto).
- Place the timing cam loosely on the crankshaft and rotate it slowly clockwise (viewed from the magneto side) until the ohm meter needle deflects from 0 to infinity  $\infty$ . That is where the points have opened. If a timing lite/tester is used, the light will go "ON".

--STOP--

- Tap the timing cam onto the crankshaft without rotating it any further (fig. 3).
- Install the rotor. Tighten rotor nut (lefthand thread) to 34 ft./lbs. of torque.
- Recheck timing by rotating the flywheel clockwise (viewed from the magneto side). As the blue mark begins to appear, the points should begin to open. The ohm meter should just begin to move from zero to infinity  $\infty$ . If timing lite/tester is used, the light will go "ON". See Note, Page 26.

Timing Spec: 2mm BTDC; Point Gap: .35 to .40mm; Spark Plug Gap: .40mm

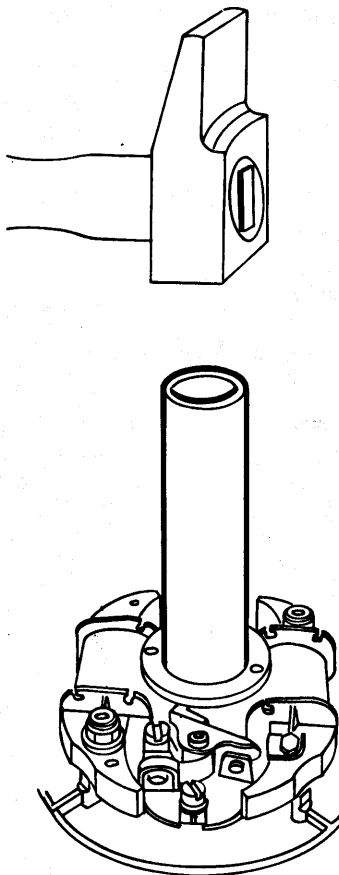

Fig. 3

## REMOVING AND REINSTALLING THE CARBURETOR

### REMOVAL:

- Remove the side covers.
- Close the fuel tap and disconnect the fuel pipe from the carburetor.
- Remove the filter box from the carburetor.
- Loosen the carburetor clamp bolt (8mm nut driver).
- Remove the carburetor from the inlet pipe.
- Loosen the chamber cover screw (screwdriver).
- Remove the carburetor (fig. 1).

### REINSTALLING ON MACHINE:

- Make sure the plastic bushing on the inlet pipe is in good condition, if so equipped.
- Make sure the nuts securing the inlet pipe to the cylinder are tightened to the correct torque (7 ft. lbs.) using a torque wrench and 10mm socket. If the inlet pipe was removed, make sure that the mating surfaces are clean. Fit a new gasket.
- Insert the throttle slide (note the position of the guiding pin) and the choke slide.

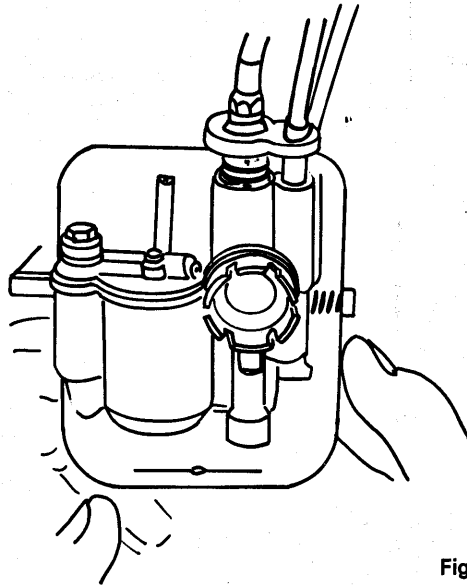
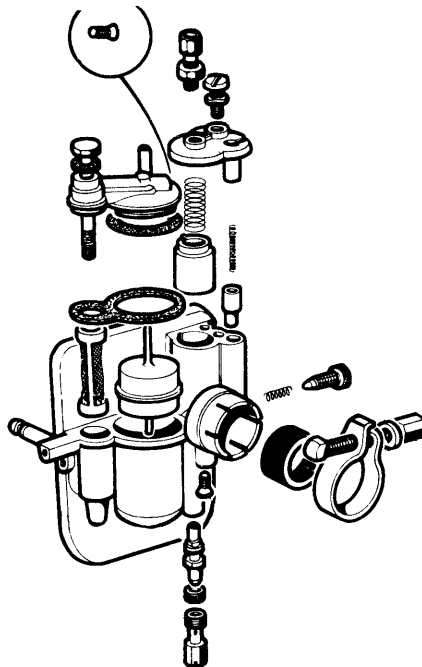

Fig. 1

REMOVING AND REINSTALLING THE CARBURETOR  
CONT'D.

- Fit the chamber cap and tighten (screwdriver) the screw securing it.
- Make certain that the throttle slide operates freely and fully opens when throttle grip is fully opened. If necessary, screw the adjustment screw on the chamber cap to keep an accurate idle.
- Fit the carburetor to the inlet pipe and push fully home.
- Position the carburetor body vertically.
- Tighten carburetor retaining clamp (8mm nut driver).
- Clean the filter screen and fit the filter plastic box.
- Connect the fuel pipe.
- Final idle adjustment can be made with the engine running by screwing or unscrewing the idle adjustment screw on the left of the carburetor.
- Fit the side covers.



Carburetor Body Complete

## DISASSEMBLING AND REASSEMBLING THE CARBURETOR

### DISASSEMBLING THE CARBURETOR:

- Remove the float bowl cover using a 10mm wrench.
- Check the paper gasket and the "O" ring.
- Loosen the screw (using a small Philips head screwdriver) or the plastic cap (fig. 1 and 2).
- Clear this pipe if necessary with an air stream.
- Fit the screw or plastic cap.
- Check the float for good condition.
- Remove the fuel jet (8mm wrench or screwdriver) and clear it if necessary with an air stream (fig. 3).
- Unscrew (screwdriver) the diffuser holder. If the diffuser cannot be easily removed, slightly push on the diffuser end in the mixing chamber. Clear the diffuser with a high pressure air line.

NOTE: Some carburetors are not equipped with a diffuser holder. These carburetors do not have a removable diffuser. Do not try to remove the diffuser from this type of carburetor. Simply leave installed and clear with an air stream.

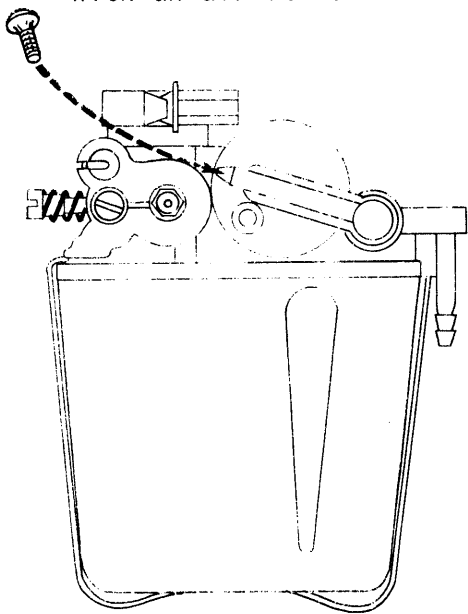

Fig. 1

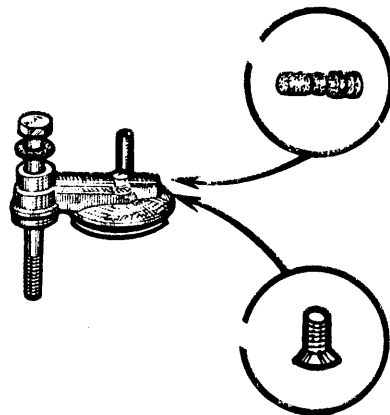

Fig. 2

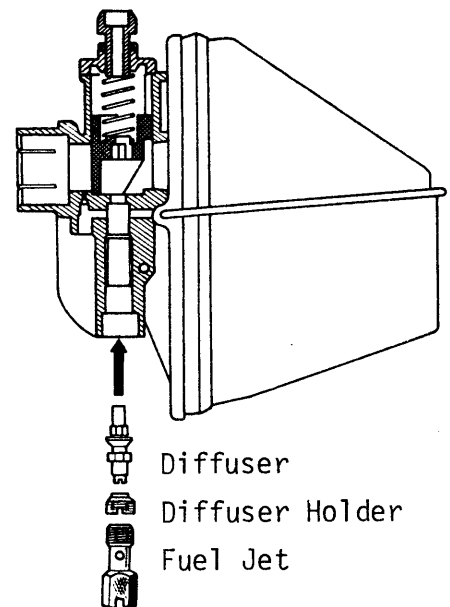

Fig. 3

DISASSEMBLING AND REASSEMBLING THE CARBURETOR  
CONT'D.

- Clean the fuel filter, the filter bowl, and the carburetor float bowl (fig. 4).
- Unscrew the plug screw (Philips head screwdriver) and if necessary, clean with an air stream (fig. 5). (This screw gives you access to the idle circuit.)
- Reinstall the plug screw.

REASSEMBLING THE CARBURETOR:

- Fit the diffuser making sure that the diffuser flattened side coincides with the carburetor or built-in flat lug (screwdriver).
- Locate the diffuser fully home.
- Fit the diffuser holder (screwdriver) and the jet (8mm wrench).

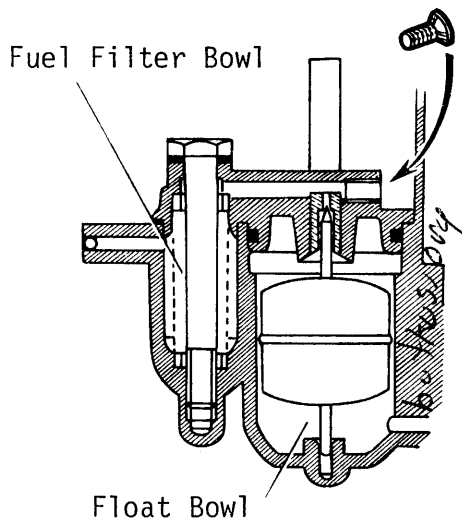

Fig. 4

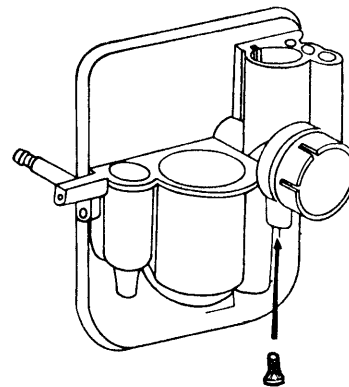

Fig. 5

## DESCRIPTION AND OPERATION OF THE "MOBYMATIC" VARIATOR

### DESCRIPTION:

- Like all Mobylettes, the Mobymatic has a primary rubber belt drive which provides the well-known smoothness and flexibility, and a secondary chain drive.
- But the Mobymatic primary drive is special. The drive pulley locked on the engine is a special collapsible one, whose cheek spacing is variable under the influence of centrifugally moved balls pushing on the cheek side which is opposite the belt. As the cheeks spread apart or close in, the winding diameter of the V-belt varies, and this in turn modifies the reduction ratio from 18.7:1 to 11.8:1. The engine tilts around its upper attachment axis. A spring tends to push the engine forward, thus ensuring belt tension.

### OPERATION:

- On starting, the engine revolves slowly as soon as it engages. The springs which push the engine forward compel the belt to rest on the smallest drive-pulley diameter. The reduction ratio is at its highest, we are in low gear. As soon as engine speed increases, the balls push the movable cheek, thus decreasing the reduction ratio, which means that for a given engine rpm, the speed of the machine is increased. If the Mobylette is on a flat road, the belt goes on increasing to larger and larger drive pulley diameters until top speed is reached. If the Mobylette engages an up-grade, the speed of both machine and engine tend to decrease. The balls exert less push on the movable cheek which then tends to move away from the fixed one, thereby decreasing the belt winding diameter. As this change of speed is continuous, the modification in reduction ratio, although fast, occurs gradually and smoothly.

The Mobymatic responds to all road conditions.

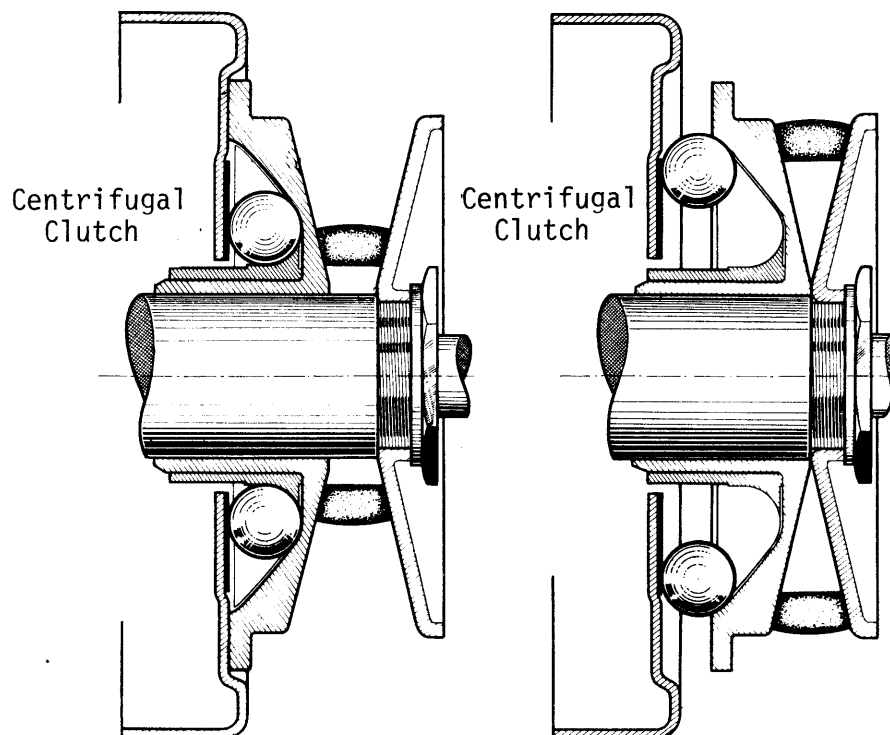



VARIATOR COMPONENT PARTS

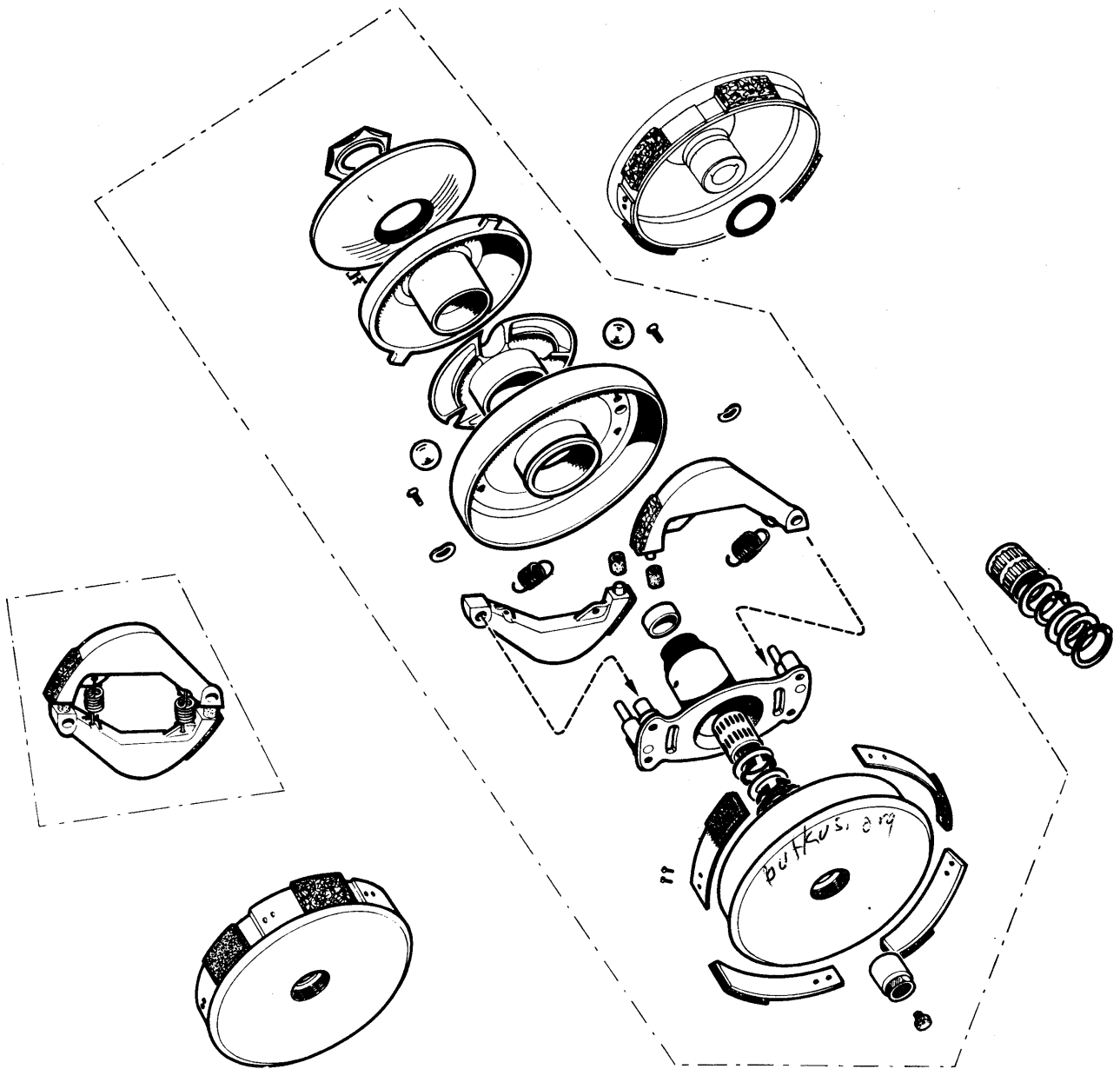

## REMOVING THE VARIATOR

- Remove the left hand side cover.
- Remove the variator cover (using a screwdriver); remove the belt.
- Unscrew and remove the spark plug.
- Fit the stroke limiter (100004) as shown in figure 1.
- Rotate the engine counterclockwise (facing the variator) and bring the piston to rest on the limiter.
- Gently loosen the variator drum locknut (14mm socket, fig. 1).
- Unscrew the grease nipple using the 6mm nut driver (fig. 2).

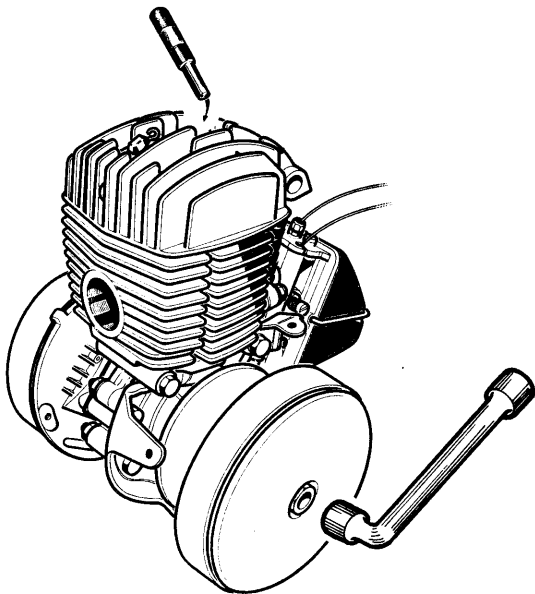

Fig. 1

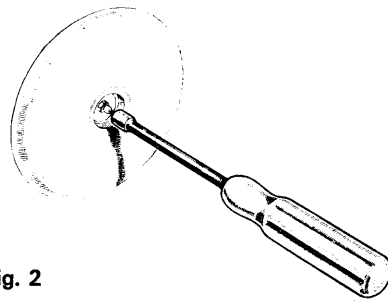

Fig. 2

## REMOVING THE VARIATOR CONT'D.

### NOTE: REPLACING THE GREASE NIPPLE

Since December 15, 1976, the crankshaft and grease nipple threads have shifted from 4 X 75 to 5 X 80.

- Rotate the engine in a clockwise direction (facing the variator) and bring the piston to rest on the limiter.
- Fit the variator puller (100020, 24 X 100) and gradually screw to the hub of the variator drum. Tighten the center bolt of the puller until the drum is free (17mm socket, fig. 3).
- Withdraw the internal ring (closing pliers, 100001) (fig. 4).
- Withdraw the shims (magnetic extractor, 100007) (fig. 5).
- Withdraw the external ring (opening pliers, 100002) (fig. 6).
- *with draw washer*  
- Variator assembly is now free for removal.

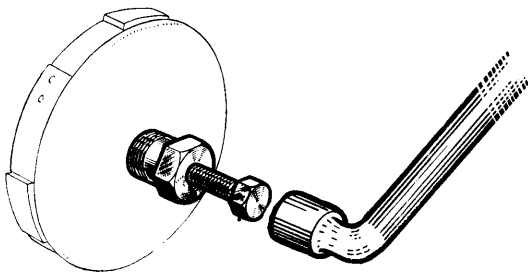

Fig. 3

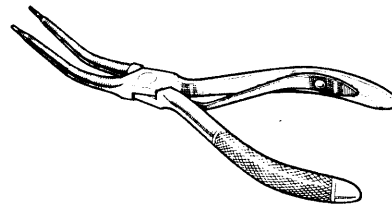

Fig. 4

*[washer/clip/washer/shim/clip (outside)]*

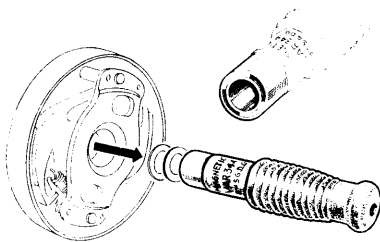

Fig. 5

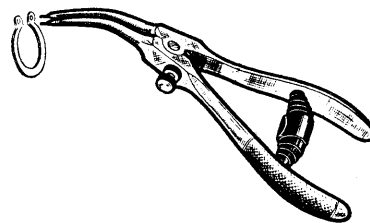

Fig. 6

# DISASSEMBLING AND REASSEMBLING THE VARIATOR

## DISASSEMBLING:

- Install the dismantling tool, No. 100026, in the jaws of a vice (fig. 1).
- Place the variator on this tool (fig. 1).
- Unscrew the lock nut (L. H. thread) on fixed cheek using a 35mm box wrench (fig. 2).
- Unscrew and remove the fixed cheek using Tool No. 100027 (fig. 3).
- Remove the sliding cheek, the ball guide, and the balls.
- Loosen and remove the 4 countersunk screws holding the drum to the hub using a screwdriver or an impact screwdriver (fig. 4).
- Remove the drum assembly with the flyweights and spring washers.
- Remove the flyweights by sliding them vertically along their pivot.

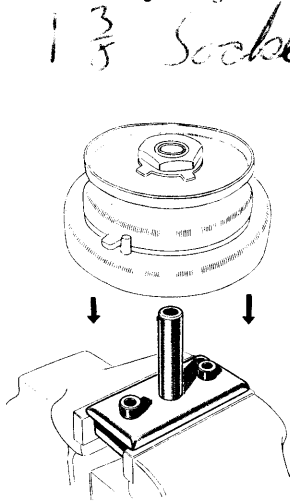

Fig. 1

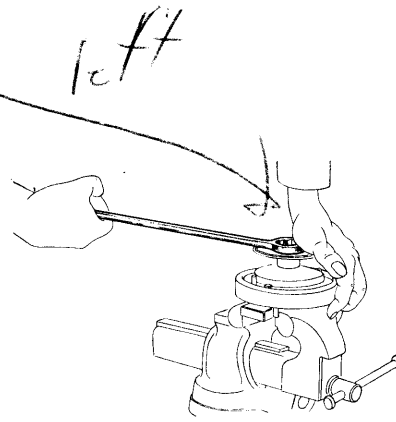

Fig. 2

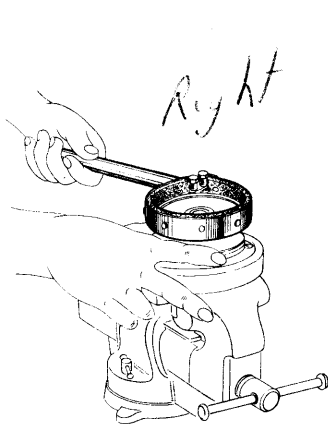

Fig. 3

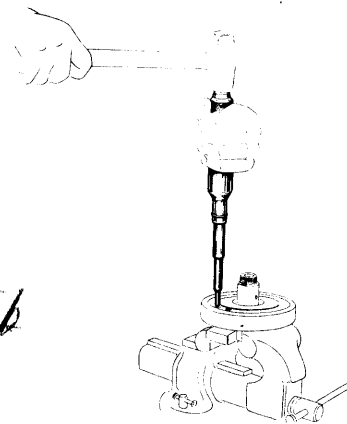
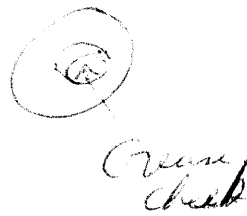

Fig. 4

# DISASSEMBLING AND REASSEMBLING THE VARIATOR

## CONT'D.

### REASSEMBLING:

- Install the variator hub on the dismantling tool, No. 100026 (fig. 1).
- Install the flyweights connected by two springs onto the pivots. When fully fitted in, they should spread out freely (fig. 5).

NOTE: Previous variators are fitted with flyweights drilled with four 2mm holes for hooking return springs. You may hook the springs in the holes nearest to each other. This will decrease springs tension and allow better starting at lower speeds.

- Fit the two spring washers on the pivots (to prevent flyweight side play, fig. 5).
- Fit the variator bell onto the hub/flyweights assembly (fig. 5).

### IN THE CASE OF NEW VARIATORS:

- Clean the thread and put some LOCTITE and fit the four countersunk screws.
- Tighten progressively and lock the screws by means of a heavy screwdriver.

### IN THE CASE OF OLD VARIATORS:

- Fit four new countersunk screws and tighten progressively. By means of a heavy screwdriver, lock the screws.
- Punch lock the countersunk screws in the notch provided for this purpose (fig. 6).

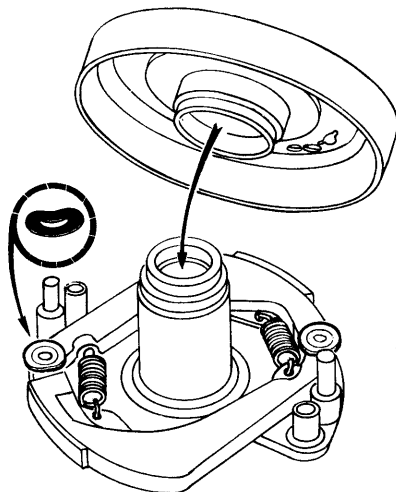

Fig. 5

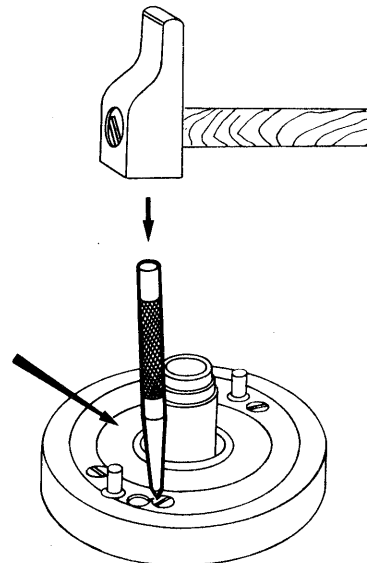

Fig. 6

*Backwards  
60° lock left*

DISASSEMBLING AND REASSEMBLING THE VARIATOR  
CONT'D.

- Take the sliding cheek (the hub turned upwards). Install the ball cage and insert the balls in the recesses (fig. 7).
- Smear a thin pellicle of grease over the ball race on the variator flange.
- Remove the variator hub from the support tool and fit the screwed fixed cheek.
- Fit the assembly on the support tool (No. 100026).

NOTE: Variators for V-belts (nominal width = 18mm) are fitted with the retaining ring and the washer placed before the fixed cheek.

- Install the fixed cheek (R.H. thread) and lock it with Tool No. 100027.
- Tighten the locknut (L.H. thread) with a 35mm box wrench.

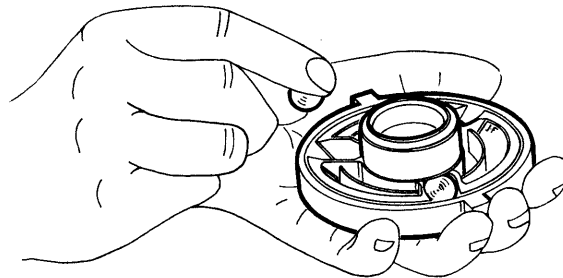

Fig. 7

## ADJUSTING AND REFITTING THE VARIATOR

- Make sure that the small ring groove (on the crankshaft tapered end) is in good condition (fig. 1).
- Clean thoroughly and remove all grease from the crankshaft threaded end (wire brush).
- Insert the caged needle bearing into the variator hub.
- Place a 0.8mm shim on the needle cage.
- Fit the small retaining ring on top of the shim (fig.2).
- Insert the other 0.8mm shims and the other ring (closing pliers). (fig. 3).

### SIDE PLAY ADJUSTMENT:

MAXIMUM SIDE PLAY: 0.1MM

- The shims and retaining rings should have a side play (slight allowance).
- If there is too much side play, perform an adjustment using 0.1mm shims (fig. 3).

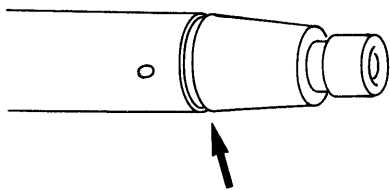

Fig. 1

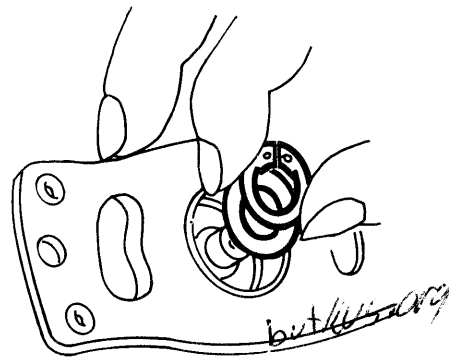

Fig. 2

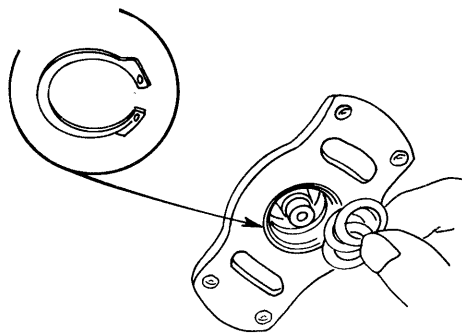

Fig. 3

ADJUSTING AND REFITTING THE VARIATOR  
CONT'D.

- Grease moderately the inner part of the hub (caged needle bearing).
- The variator can now be reinstalled (fig. 4).
- Drive the variator fully home. It will locate itself in the right position.
- The assembly will rotate freely without play if the side play has been adjusted as described above.
- Bring the piston to rest on the stroke limiter and fit the variator drum (do not forget the o-ring on the drum hub).
- Tighten the nut to 22 ft. lbs. (torque wrench) after having applied a single drop of LOCTITE (fig. 5).
- Fit the grease nipple (6mm nut driver) refer to NOTE, Page 39.
- Remove the stroke limiter, fit the spark plug and radio suppressor.
- Fit the belt, the variator cover, and side cover.

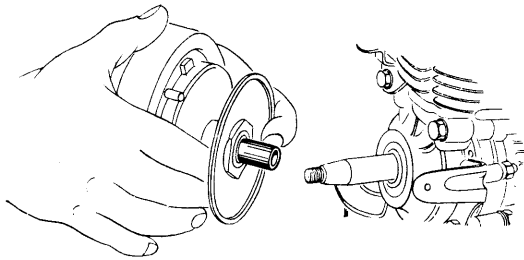

Fig. 4

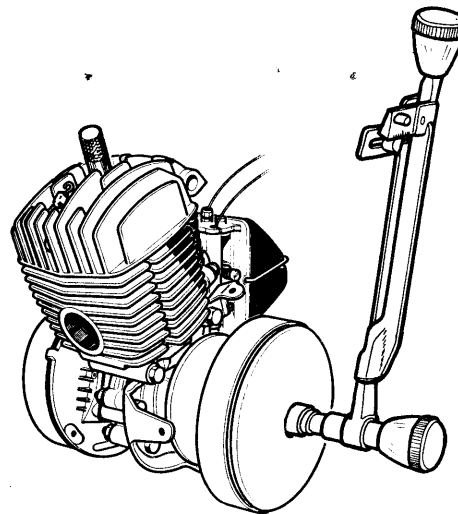

Fig. 5



# REMOVING - REFITTING - DISASSEMBLING - REASSEMBLING THE CLUTCH

## REMOVING THE CLUTCH:

- Do not remove the belt guard. Slip the drive belt off from the pedal shaft pulley.
- Refer to page 38 (same procedure as for the variator).

## DISASSEMBLING THE CLUTCH:

- Remove the caged needle bearing.
- Moderately clamp the pulley on the clutch in a vice fitted with copper jaws.
- Loosen and remove the two countersunk screws (impack screwdriver) (fig. 1A).
- Remove the counter flange (fig. 1B).
- Remove the two spring washers.
- Remove the flyweights by sliding them vertically along their pivot (carefully note flyweights position, fig. 1C).

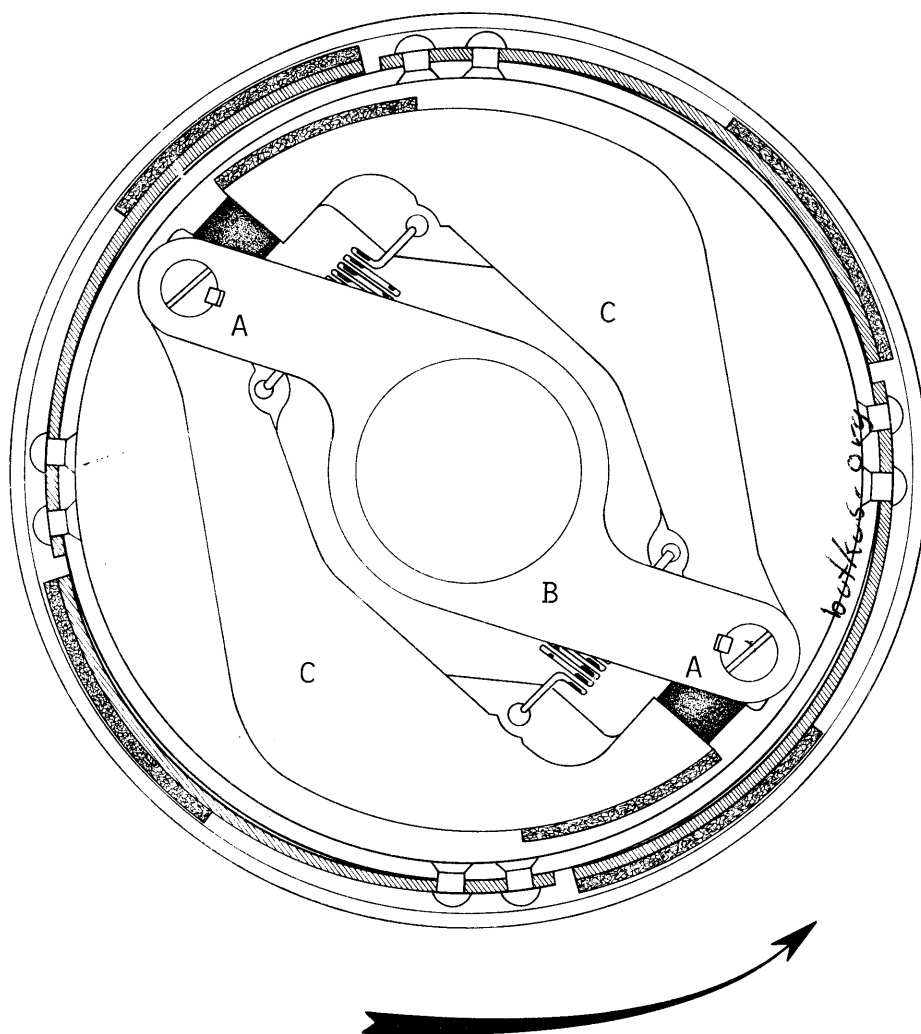

Direction of Rotation

Fig. 1

## REMOVING - REFITTING - DISASSEMBLING - REASSEMBLING THE CLUTCH

### REASSEMBLING THE CLUTCH:

- Fit both flyweights (connected with two springs) on the mounting pillars (fig. 1C).
- Place both spring washers on the mounting pillars.
- Place the counter flange on the washers (fig. 1B).
- Secure the counter flange with two new countersunk screws (fig. 1A).
- After final tightening, punch lock both screws in the notches provided for this purpose (fig. 1A).

### SIDE PLAY ADJUSTMENT AND REFITTING THE CLUTCH:

- Refer to pages 43 and 44 (same procedure as for variator).
- Fit the belt on clutch pulley.

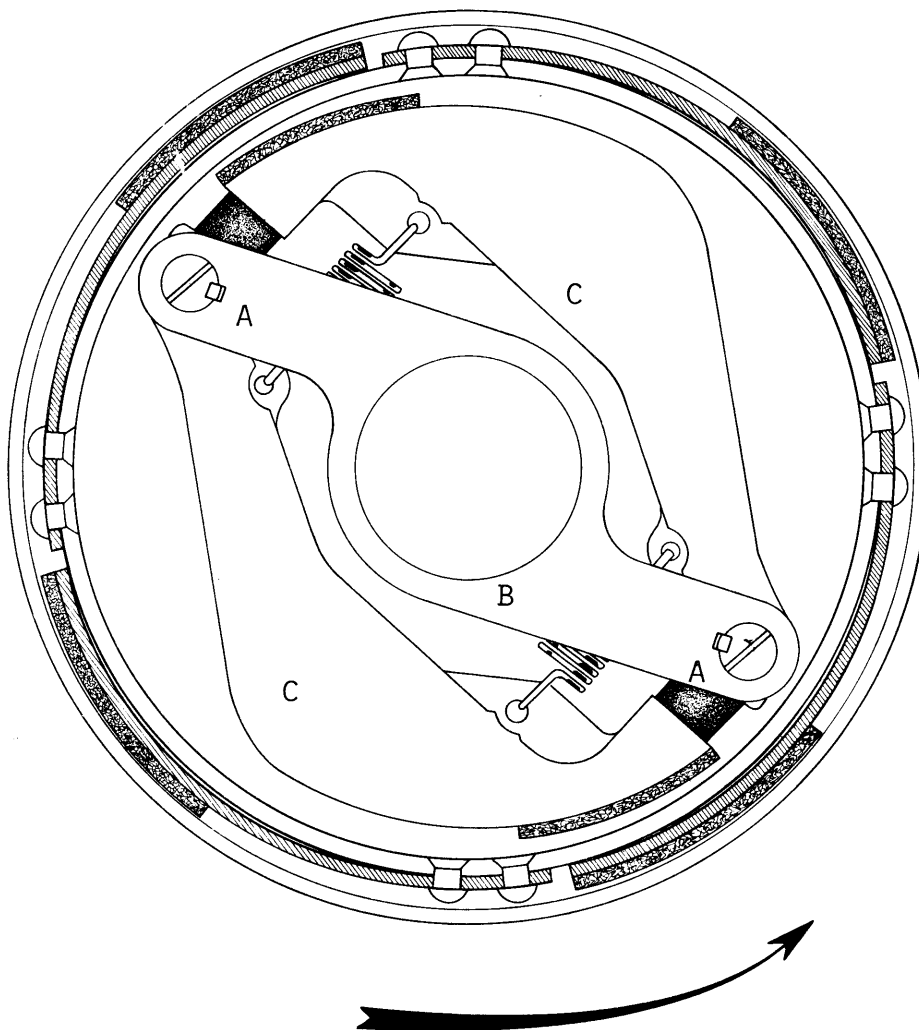

Direction of Rotation

Fig. 1

## REMOVING AND REFITTING THE DRIVEN PULLEY

### REMOVAL:

- Remove the L.H. side cover using a screwdriver.
- It is unnecessary to remove the drive chain, but if you need to replace it, remove the "master" link.
- In the case of a variator engine, remove the belt cover (screwdriver).
- Remove the pedal pin nut (11mm wrench) and drive out the L.H. crank cotter pin.
- Remove the pedal crank with the pedal attached.
- Slip the drive belt off from the pulley groove.
- Using a multi-lock pliers remove the dust cap (fig. 1).
- Remove the retaining ring (opening pliers, No. 100002) and the thrust washer (fig. 2).
- Turn the engine engagement lever to V (engine disengaged).
- The pulley assembly can now be pulled off the shaft. Hold the dual sprocket. Rotate the pulley and pull on it.
- Remove the pulley.
- Lift the chain off the rear sprocket while rotating the wheel and remove the dual sprocket.

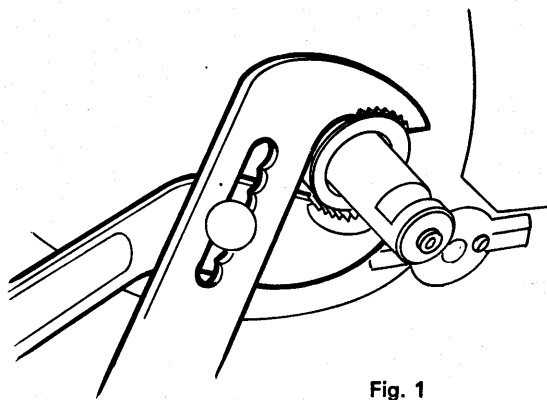

Fig. 1

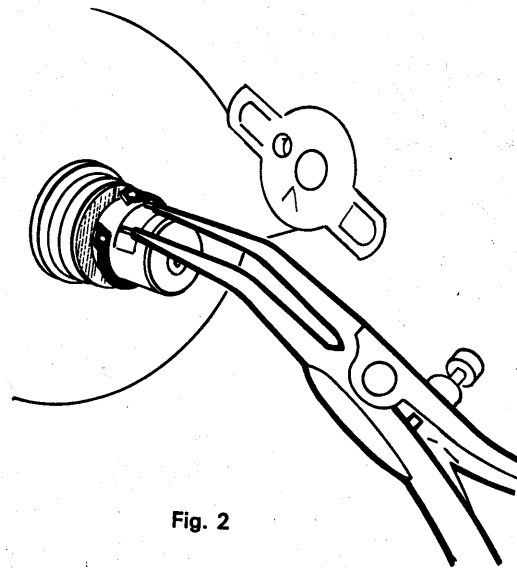

Fig. 2

## REMOVING AND REFITTING THE DRIVEN PULLEY CONT'D.

### REFITTING:

- Fit the dual sprocket on the pedal shaft (smaller teeth facing the frame).
- Fit the chain on the dual sprocket making sure that the "master" link clip is facing the correct way. The closed end of the spring clip must face the direction of chain travel (fig. 3).
- Fit the chain on the rear wheel sprocket.
- Place the pulley (engine engagement lever set to V) on the pedal shaft.
- Center the dual sprocket manually and fit it on pulley hub.
- Press on the pulley to drive the sprocket fully home.
- Fit the thrust washer and the retaining ring (opening pliers No. 100002).
- Fit the dust cap (replace it if it was damaged during dismounting).
- Fit the belt, the cover (if variator engine) and side cover.
- Make certain the chain is correctly tensioned (this operation must be done with a rider on the machine).
- The adjusting of the chain is carried out by means of the chain adjusters situated at the end of the swing arm. Don't forget to loosen the wheel axle nuts (8mm wrench) (fig. 4).

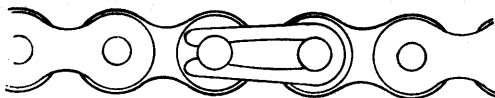

Fig. 3

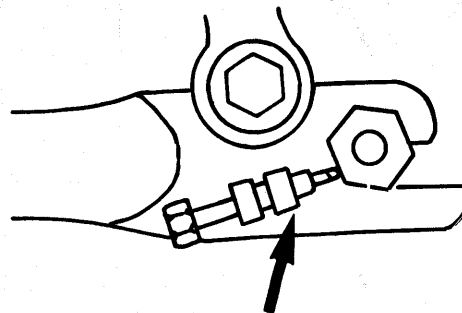

Fig. 4

## REMOVING AND REFITTING THE CRANKGEAR

### REPLACING CRANKGEAR BUSHINGS

#### REMOVING THE CRANKGEAR:

- Remove the driven pulley (refer to page 47 ).
- Remove the retaining ring (opening pliers, No. 100002) and thrust washer (fig. 1).
- Remove the R.H. side cover.
- Release the chain tensioner (fig. 2).
- Slip the pedal chain off or remove it if it is due for replacement.
- Remove the crankgear with the R.H. crank and thrust washers (disassemble the crank if the crankgear is due for replacement: 11mm wrench).

#### ADJUSTING THE CRANK AXLE SIDE PLAY:

- Fit the thrust washer on the crank axle.
- Fit the crank axle into the bushings.
- Fit the ring and thrust washer (fig. 1).
- The shaft should have almost 0.1mm side play.
- If necessary, perform a correct adjustment by using shims (No. 14863, 0.1mm; No. 14865, 0.3mm).

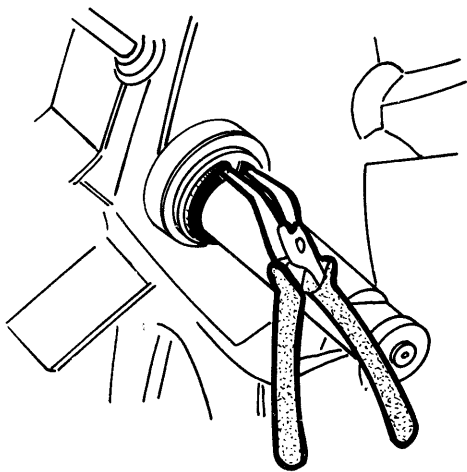

Fig. 1

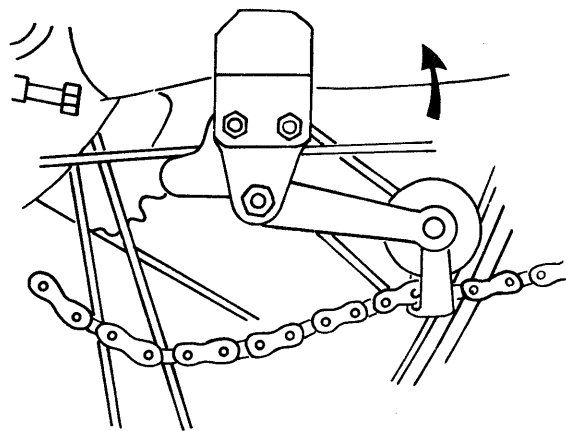

Fig. 2

REMOVING AND REFITTING THE CRANKGEAR  
REPLACING CRANKGEAR BUSHINGS  
CONT'D.

REFITTING THE CRANKGEAR:

- Reverse the removal procedure.
- Take care in positioning the "master" link in the correct way (see page 48).

REPLACING CRANKGEAR BUSHINGS:

- Remove the driven pulley (refer to page 47).
- Remove the crankgear (see preceding page).
- Drive the bushing out by using a steel drift punch (12mm) (fig. 3).
- Drive the remaining bushing out with the 20mm steel tube.
- Fit new bushings by using Tool No. 100009 (fig. 4).
- Insert the crank axle in the bushings. The axle should turn freely without play (if necessary use a 16mm reamer on the bushings).
- Fit the crankgear and the pulley (see above and page 48).

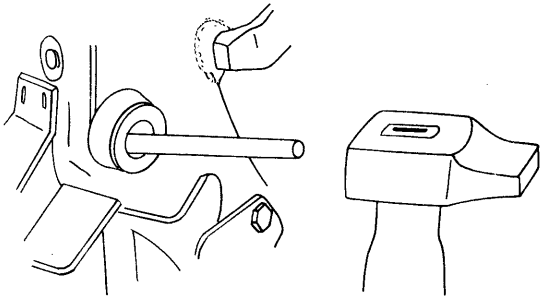

Fig. 3

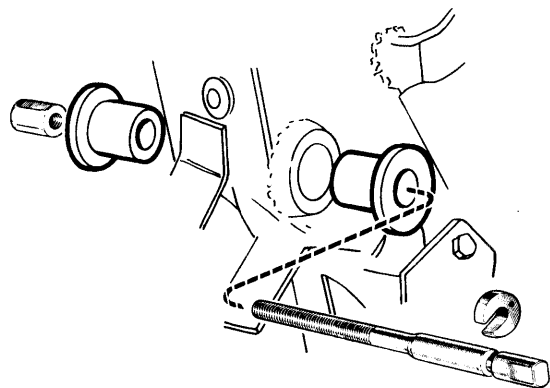

Fig. 4

# REPLACING UPPER ENGINE MOUNTING FLEXIBLE BUSHINGS (MODELS 40 AND 50)

TOOL NO. 100024 IS ABSOLUTELY NECESSARY TO EFFECT THESE OPERATIONS

- Remove both side covers using a screwdriver.
- Remove the belt from the pulley groove.
- Loosen the upper engine mounting nut (12 and 13mm wrenches).
- Drive out the upper engine mounting axle while holding the engine.
- Let the engine lean downwards but place a block under it for support.
- For removal or installation operations, the flexible bushings must be removed or installed from inside to outside.

## REMOVING THE FLEXIBLE BUSHING:

- Position the tool in alignment (fig. 1). Hold the nut with a 17mm wrench and screw in puller's screw by using a 12mm wrench.

## POSITIONING THE FLEXIBLE BUSHING:

- Insert the stop washer (this will locate the bushing correctly in the frame) as shown on fig. 2.
- Position the flexible bushing (chamfered end) on the screw and proceed as when removing the flexible bushing.
- Replace if necessary the left flexible bush insulation ring.
- Fit the upper engine mounting axle, tighten the nut without locking it (refer to the NOTE on page 11).

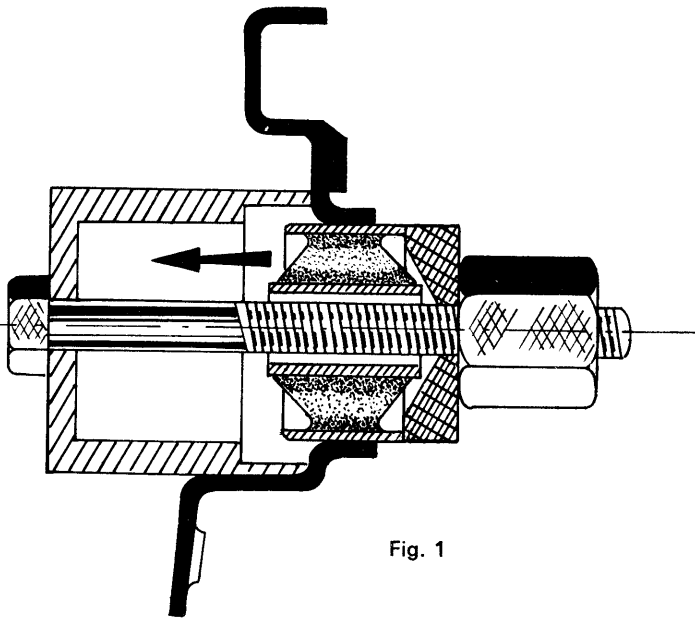

Fig. 1

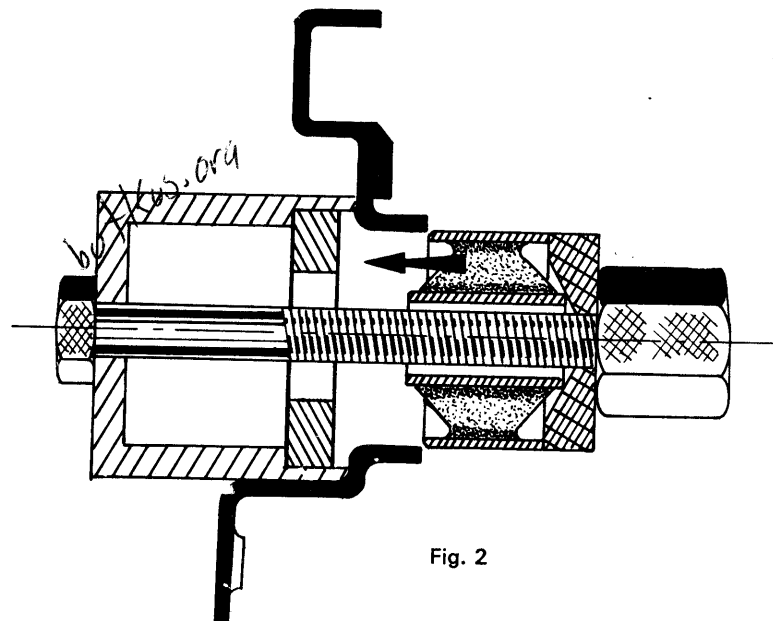

Fig. 2

## REPLACING UPPER ENGINE MOUNTING FLEXIBLE BUSHINGS (MODEL 7)

NOTE: All service operations regarding the engine and the frame indicated throughout our REPAIR OPERATIONS are valid for moped type "7".

TOOL NO. 100024 IS ABSOLUTELY NECESSARY TO EFFECT THIS OPERATION

- Remove both side covers using a screwdriver.
- Slip the belt off from the pulley groove.
- Loosen the nut (10mm socket) on the lower engine mounting screw and remove it.
- Loosen the two nuts (13mm socket) on the upper engine mounting.
- Remove the engine and let it detach from the frame. Support the engine by placing a block under it.
- For removing or fitting operations, the flexible bushes will be removed or fitted from front to rear of the machine (fig. 1 and fig. 2).

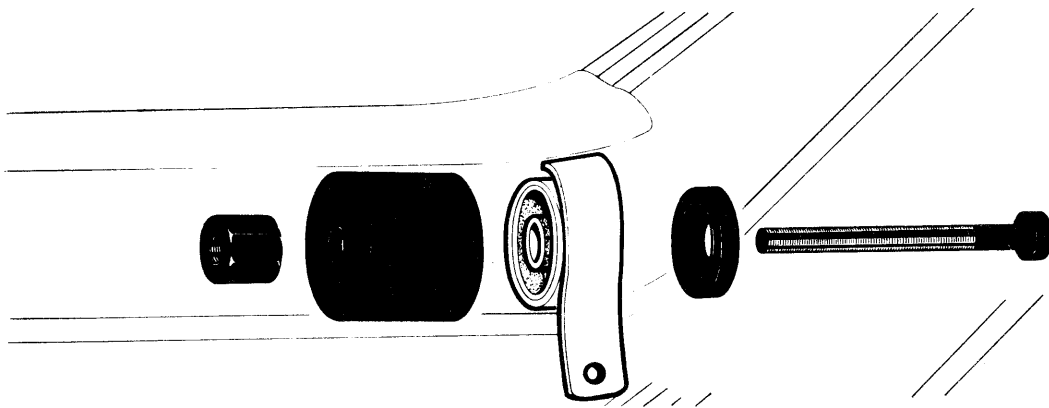

Fig. 1 - Location of parts for bushing removal

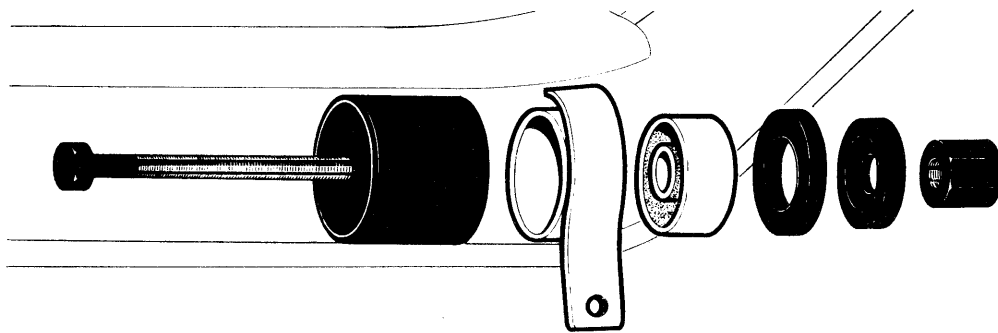

Fig. 2 - Location of parts for bushing installation



REPLACING UPPER ENGINE MOUNTING FLEXIBLE BUSHINGS (MODEL 7)  
CONT'D.

REMOVING THE FLEXIBLE BUSHING:

- Align the tool as shown in fig. 1, and hold the nut with a 17mm wrench and screw in the tool's screw using a 12mm wrench.

FITTING THE FLEXIBLE BUSHING:

- Reverse the body of the tool and insert the screw in it.
- Fit the flexible bushing (chamfered side) on the screw, pile up the two washers of the tool as indicated (fig. 2) and screw the nut until the wider washer rests against the flexible bushing housing welded to the frame.

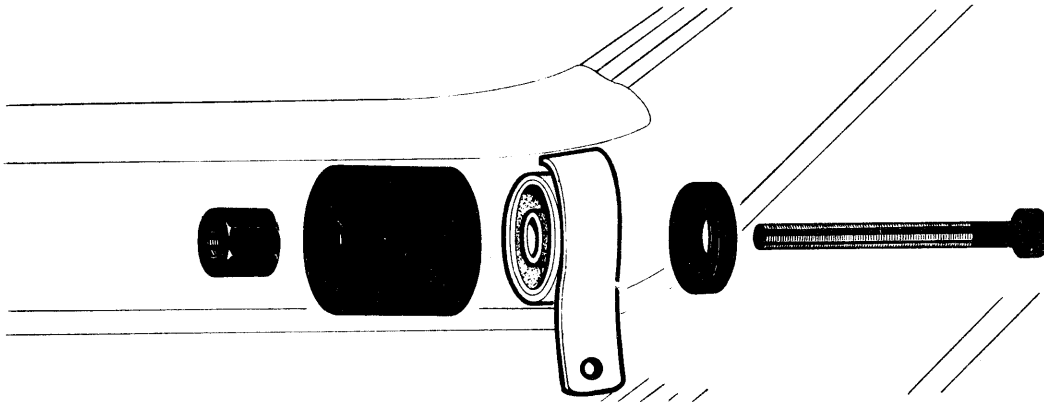

Fig. 1 - Location of parts for bushing removal

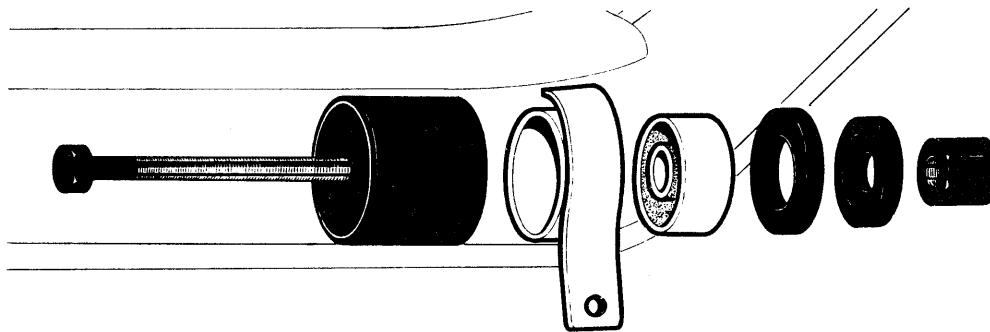

Fig. 2 - Location of parts for bushing installation

## REPLACING CABLES

### FRONT OR REAR BRAKE CABLE:

- Loosen the cable end using a 6mm open wrench and slide the inner wire out through the brake lever (fig. 2).
- Tighten the brake adjuster at the handgrip fully (fig. 3).
- Grease the new inner wire and feed it through the lever anchor pin, the adjuster and outercasing.

When replacing the rear brake inner wire, make sure that the ferrule is positioned correctly.

### ADJUSTMENT: Fig. 1

- Hold the cable with pliers (right hand). Push on the cable grip with a second pair of pliers. Pinch the inner wire at the point where the cam lever touches. Release the end of the cable and tighten cable grip screw (fig. 2).

If necessary, adjust the brakes using the adjusters on the levers (fig. 3).

### THROTTLE CABLE:

Remove the R.H. engine cover and tilt the carburetor (to the left side) by loosening the carburetor clamp (8mm nut driver). Remove the screw on the mixing chamber cover. Remove the cover complete with the throttle slide and choke slide (screwdriver).

- Loosen the cable lock from the throttle twist grip (6mm open wrench). Pull out the inner wire.
- Reassemble in reverse sequence and grease the new inner wire before sliding it into the outercasing.
- Fit the carburetor and tighten the clamp.
- Make the final adjustment on the screw located on the mixing chamber cover and make certain the throttle slide works freely.

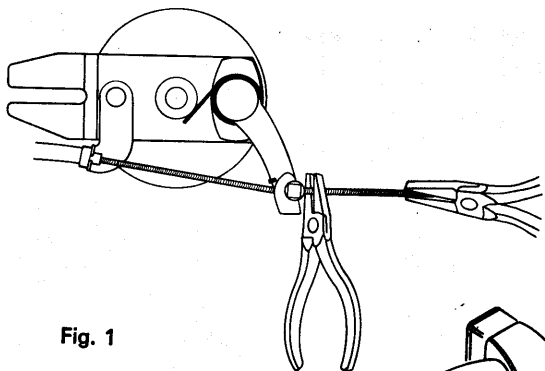

Fig. 1

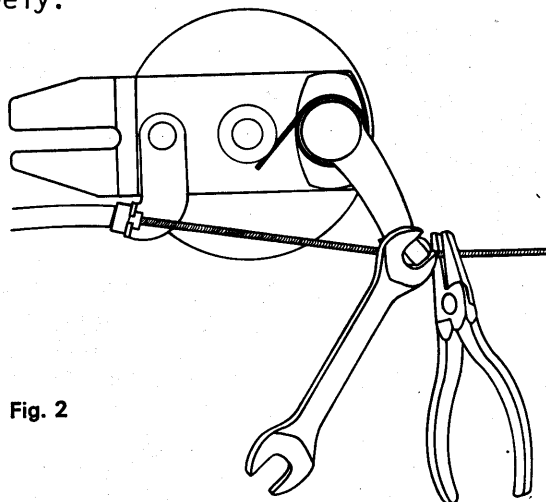

Fig. 2

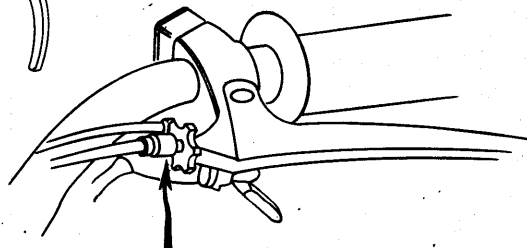

Fig. 3

## REPLACING CABLES CONT'D.

### CHOKE CABLE:

- Follow the procedure as described for the throttle inner wire.
- Slacken the nut at the choke lever (8mm open wrench) and pull the inner wire out from the bottom of the choke slide.
- Reverse the procedure to reassemble after having lubricated the replacement inner wire and feed it up through the choke slide.
- Adjust the tension at the choke lever adjuster (a small amount of free movement is required and should not exceed  $\frac{1}{4}$ ", fig. 4).

### DECOMPRESSOR CABLE:

- Loosen the cable end using a 6mm open end wrench.
- Remove the radio suppressor and depress the decompressor spring using a screwdriver and remove the ferrule from its holder.
- Pull out the inner wire from the outercasing.
- Grease the new inner wire and reroute it through the outercasing and into the shouldered ferrule. Reverse disassembling procedure.
- Adjust the cable tension at the decompressor adjuster on the twist grip (a small amount of free movement is required and should not exceed  $\frac{1}{4}$ ", fig. 5).

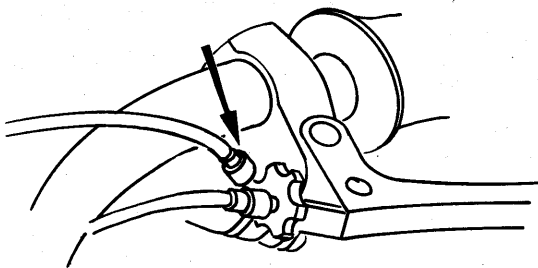

Fig. 4

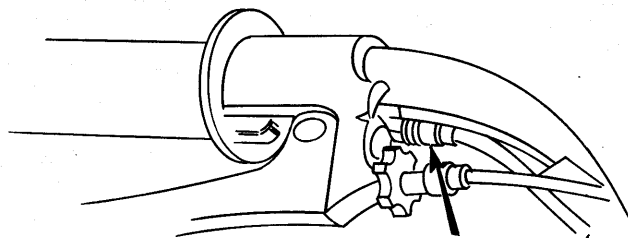

Fig. 5

## REPLACING THE FRAME

- Remove both side covers.
- Drain the fuel tank.
- Remove the radio suppressor and disconnect the decompression cable.
- Remove the L.H. black plastic cover (fig. 1).
- Remove the screw on the mixing chamber cover, and the cover complete with throttle slide and choke slide from the carburetor.
- Remove the outercasing retainer together with the ignition coil (8mm wrench, fig. 2).
- Disconnect the rear brake inner wire, remove the solderless nipple and the outercasing shouldered end.
- Disconnect the four-way connector, the wires outside the flywheel magneto, and zener diode straight terminals.
- Remove the R.H. black plastic covers.
- Detach all electric leads.
- Set the machine on a lift bench and clamp the rear wheel.

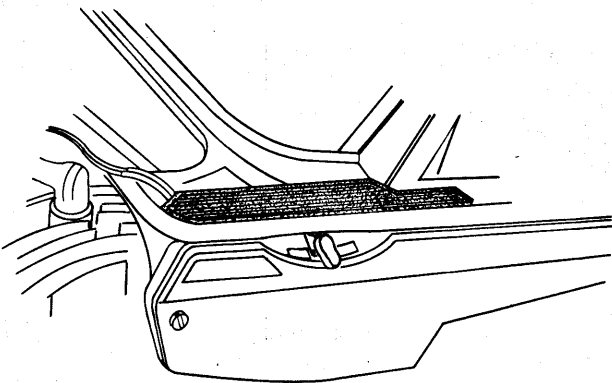

Fig. 1

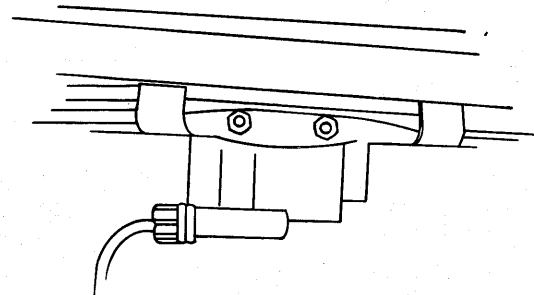

Fig. 2

## REPLACING THE FRAME

CONT'D.

- Unscrew and remove the nuts securing one of the "U" clamps on the handlebar. (This is not required if the machine is fitted with tall "U" clamps. Use wrench No. 1229 to remove the top steering locknut).
- Loosen the nuts securing the other "U" clamp.
- Remove the serrated mounting blocks.
- Unscrew and remove the steering locknut (32mm wrench) and the washer.
- Flatten the lock plate and remove the bottom pivot screw (32mm wrench).
- Remove the front wheel assembly, fork, handlebars, and controls.
- Remove the steering head set (refer to page 64 ).
- Remove the belt cover.
- Disconnect the fuel pipe, and remove the engine assembly with the carburetor (refer to page 8 ).
- Remove the driven pulley, the crankgear, and the chains (refer to pages 47 - 50).
- Remove the loading springs and the stop bracket (10mm wrench, fig. 3).

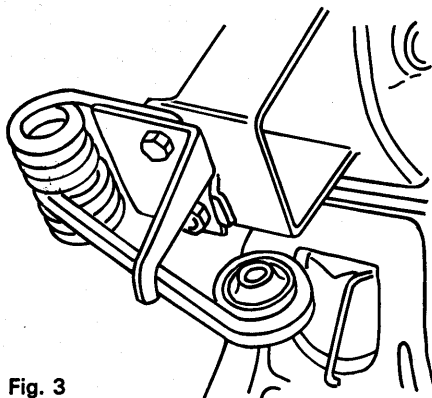

Fig. 3

## REPLACING THE FRAME

### CONT'D.

- Remove the saddle and the clamp around the frame seat pillar (13mm wrench).
- Remove the fuel cap, decals, chrome strip and tool box covers.
- Remove the zener diode (10mm wrench), if equipped.
- Remove the shock absorber upper mounting bolts (13mm wrench).
- Remove the self-locking nut (17mm wrench) and drive out swing arm shaft.
- Remove the swing arm complete with shock absorbers and the rear wheel (fig. 4).
- Remove the rear fender with wiring and luggage rack lower support brackets (refer to page 75).
- Remove the luggage carrier rack and luggage rack upper support brackets (10mm wrench and Philips screwdriver).
- Remove the fuel tap (14mm open wrench). Make sure the rubber seal is in good condition (fig. 5).
- Remove the plastic strips from rear frame arms and the grommet from the lower part of the frame.
- Remove the center stand (refer to page 69).

### REFITTING THE FRAME:

- Reverse the procedure. Fit new crankgear bushings (Page 50) and new flexible bushings (Page 51).

NOTE: Do not forget to stamp the frame number on the new frame in the same location as the old frame.

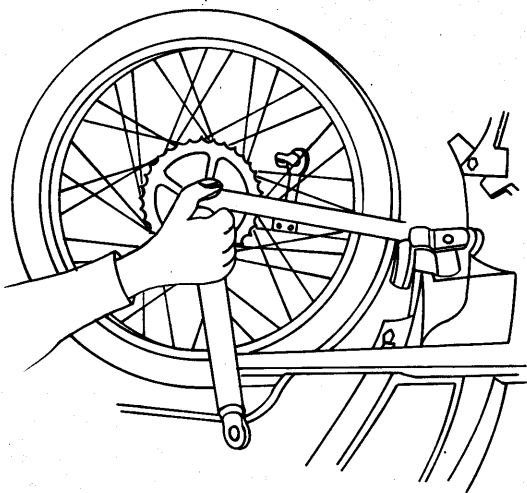

Fig. 4

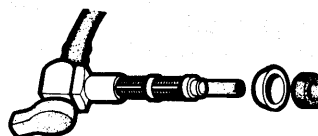

Fig. 5

## REMOVING THE MAIN FORK ASSEMBLY

- For all operations on the front fork, fasten the rear wheel (the front wheel will clear the ground) with a clamp similar to that shown in fig. 1.
- Remove the four nuts and washers under the handlebar "U" clamps (10mm wrench).
- Remove the "U" clamps complete with wedges. Let the handlebar hang down.
- Remove the headlamp assembly and disconnect the wires from the sealed beam.
- Disconnect the wires at the headlamp switch.
- Disconnect the wires from the horn, disconnect the speedometer control from speedometer drive unit and the front brake control.
- Remove the outercasing ferrule (10mm wrench) and free the brake cable from the fender bracket.
- Remove the upper nuts together with the fork caps and rubber washers from the upper end of the fork (slotted screwdriver, No. 100012, fig. 2).

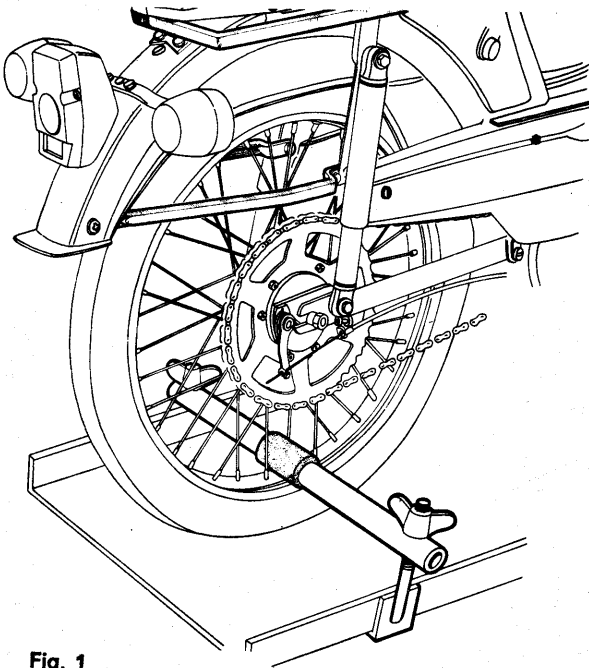

Fig. 1

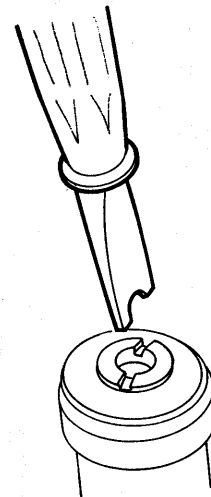

Fig. 2

## REMOVING THE MAIN FORK ASSEMBLY CONT'D.

- Remove the front wheel with the fork plungers.
- Remove the top steering lock nut and washer (32mm wrench, fig. 3).
- Flatten the lock plate and remove the bottom fork stem retaining bolt (wrench, No. 100019, fig. 4).
- Press against the fork pivot and lower fork plate with a screwdriver to free the pegs (fig. 5).
- Pull on the main fork assembly to free the lower fork plate and lift to free the upper part.
- Remove the headlamp and the horn (10mm wrench) and fit them to the new main fork assembly. (Do not forget the ground leads on the headlamp lower mounting screw.)

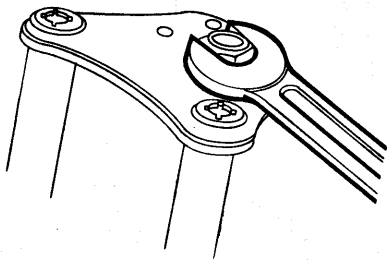

Fig. 3

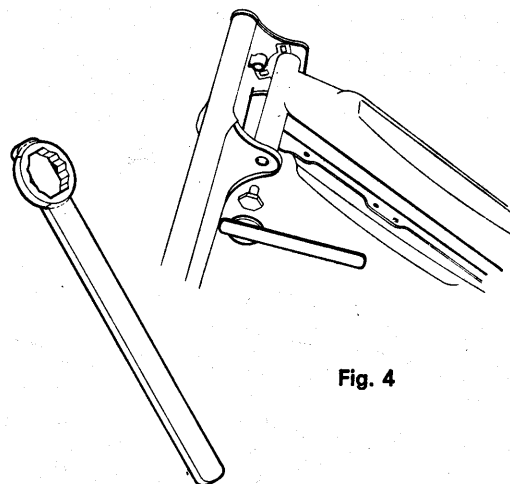

Fig. 4

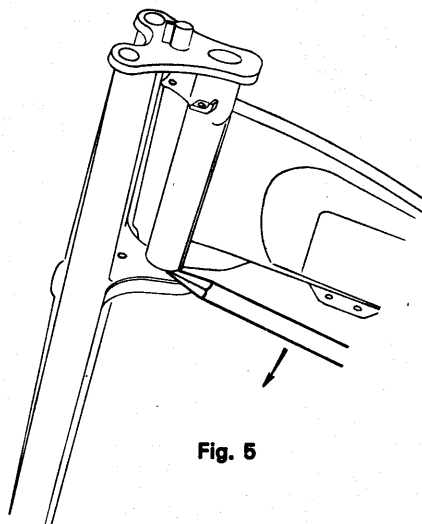

Fig. 5



REFITTING THE MAIN FORK ASSEMBLY  
REMOVING AND REFITTING THE FORK COMPLETE

- Reverse dismantling procedure.
- Make sure that the lower plate pegs are positioned in the slots of the fork pivot.
- If necessary, replace fork bushings and spacers (refer to page 62 ).
- Always fit a new lock plate on the bottom pivot screw.

REMOVING AND REFITTING THE FORK COMPLETE:

- Remove the front wheel (refer to page 66 ) and the fender (refer to page 76 ).
- You need not remove the fork caps retainer nuts (fig. 1).
- Follow the instructions given for the main fork assembly removal and refitting.

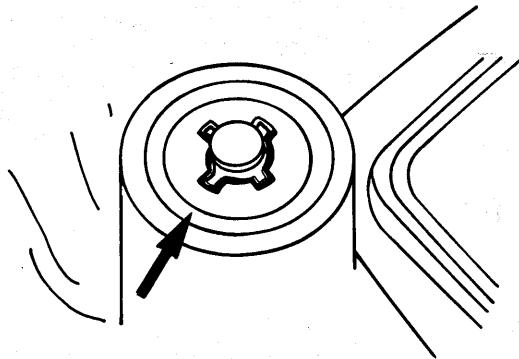

Fig. 1

## REPLACING FORK BUSHINGS AND SPRINGS

- Disconnect the speedometer cable.
- Disconnect the front brake control cable.
- Remove the outercasing shouldered end of the front brake cable and free the cable from fender support.
- Remove the fork cap retainer nuts (slotted screwdriver, No. 100012).
- Remove the wheel complete with fork plungers and springs.
- Remove the dampers.
- Remove the fork seals (fig. 1).
- Extract the bushings and sleeves with the 2-jaw puller, No. 100006 (fig. 2).
- Insert a new set of bushings and sleeves in each fork tube.
- Make sure the bottom fork seals are in good condition: otherwise replace them (fig. 3).
- Fit new fork springs if the old ones were broken.
- Fit the dampers and the fork seals on the plungers.
- Coat the springs with grease and fit the wheel with plungers back into the the fork shell.
- Fit the rubber washers, cups, and tighten the upper nuts (slotted screwdriver, No. 100012).

NOTE: Make sure the top struts of the fork plungers are lined up with the fork housing before tightening down on the slotted nut with Tool No. 100012 (fig. 4 and 5).

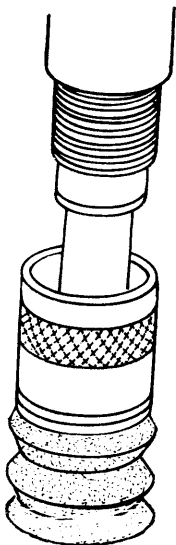

Fig. 1

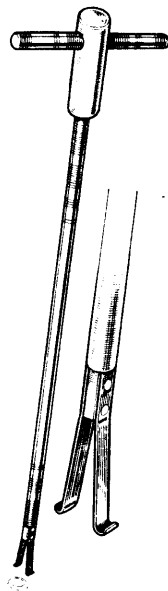

Fig. 2

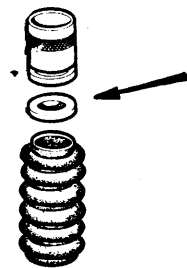

Fig. 3

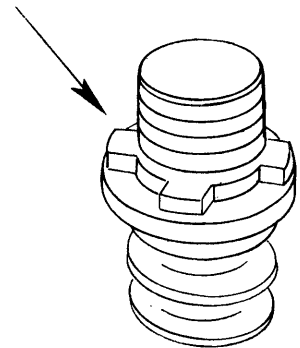

Fig. 4

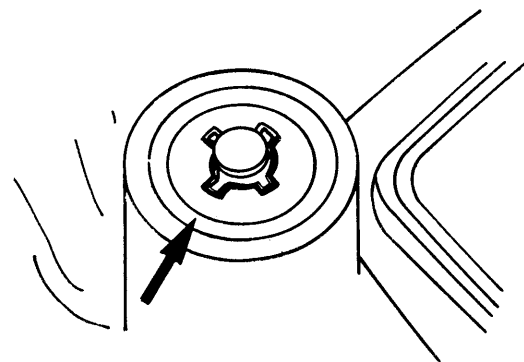

Fig. 5

## REMOVING THE HANDLEBARS

- Slacken the locknut under the twist grip and remove the screw (8mm wrench and screwdriver, fig. 1).
- Remove the twist grip sleeve.
- Free the throttle and decompressor controls from the retaining bracket on the fork upper plate (fig. 2).
- Slacken the screw securing the twist grip body to the handlebars (fig. 1).
- Insert a screwdriver blade between the rubber grip and handlebar tube (fig. 3).
- Tilt the machine slightly and inject some oil drops in the space opened by the screwdriver (fig. 3).
- Remove the rubber grip (fig. 3).
- Slacken the screw securing the left hand grip body.
- Remove the four nuts under the handlebar "U" clamps.
- Remove the left hand grip body.
- Remove the handlebars.

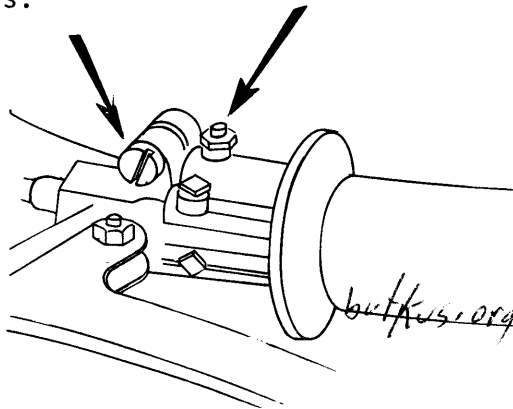

Fig. 1

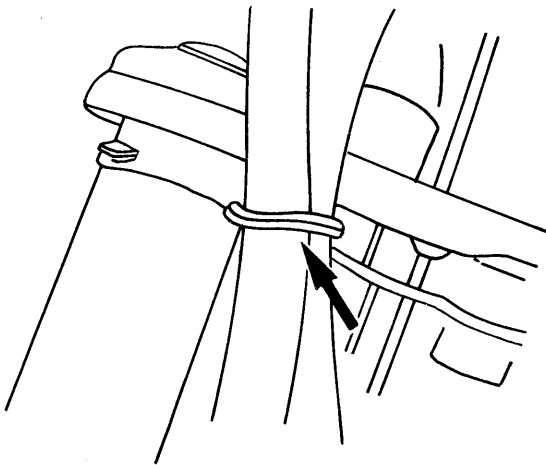

Fig. 2

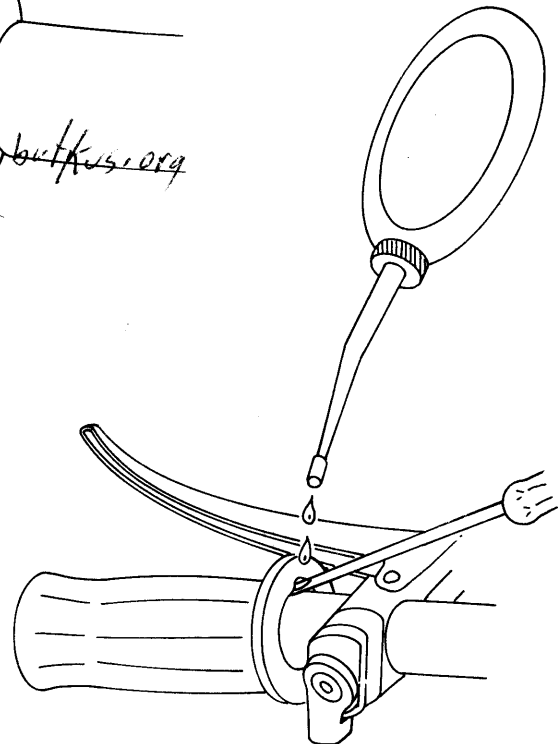

Fig. 3

## REMOVING THE STEERING HEAD ASSEMBLY

### REMOVAL:

- Remove one "U" clamp (10mm wrench). This is not necessary for tall "U" clamps. Remove the top steering lock nut using Wrench No. 1229 (fig. 1).
- Slacken the nuts securing the other "U" clamp and remove the wedge under the "U" clamp already removed (fig. 1).
- Flatten the lock plate and remove the lower pivot screw (Wrench No. 100019).
- Remove the fork with the wheel without disconnecting any wires.
- Let this assembly hang to one side and insert a screwdriver or a hardwood block through the spokes to lock the wheel (fig. 2).
- Hold the steering head stem with interlocking joint pliers and slacken the upper steering cone.
- Remove the steering head stem, collect the steering head steel balls, and pull out the upper and lower cups by using a cup puller (fig. 3).

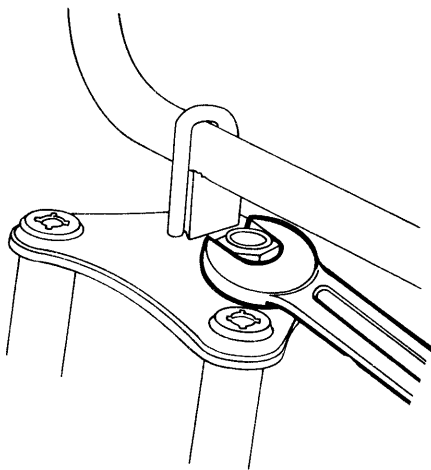

Fig. 1

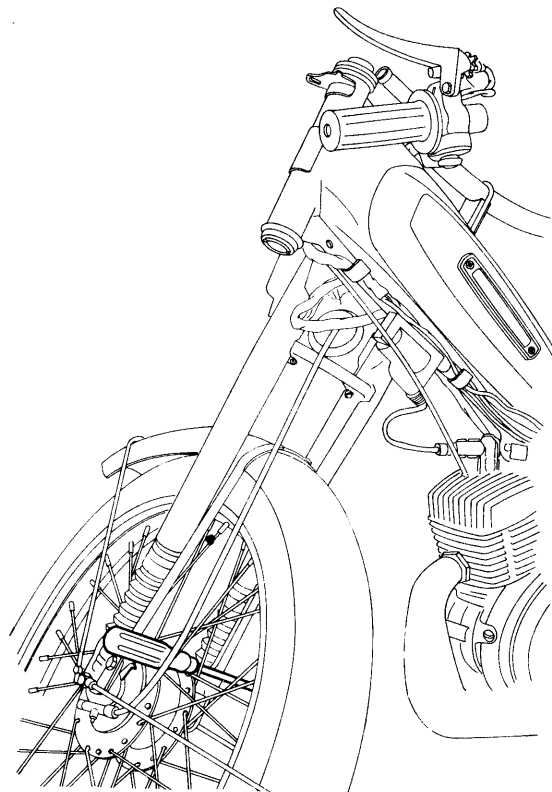

Fig. 2

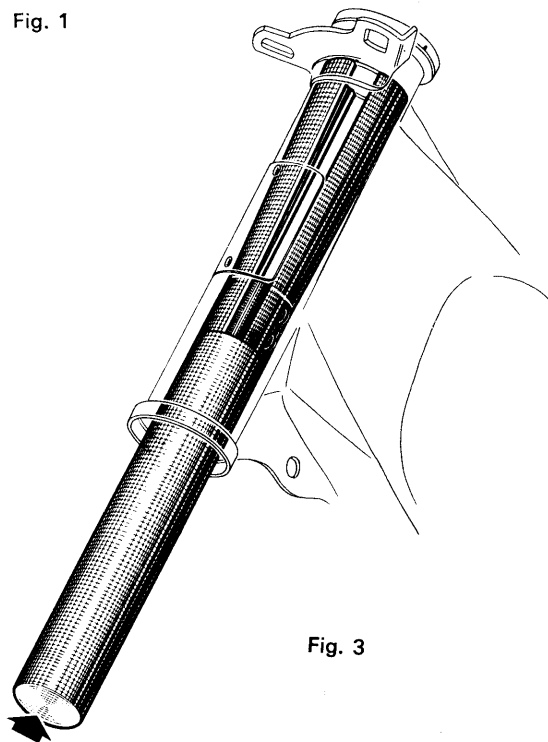

Fig. 3

## REFITTING THE STEERING HEAD ASSEMBLY

- Insert the bottom and top cups into the frame steering tube (fitting tool, No. 100016, fig. 1).
- Pack the top cup and pivot stem cone with grease to make ball fitting easier.
- Place the balls (26 balls) on the pivot stem cone and insert it in the frame steering tube.
- Fit the other 26 balls in the top cup.
- Screw in the top cone. Hold the pivot stem with interlocking joint pliers and straighten the cone with the hand (fig. 2).
- Fit the assembly (wheel, fork, and handlebar).
- Fit the "U" clamp and wedge.
- Tighten the four "U" clamp nuts (10mm wrench).
- Make sure there is no up and down play in the steering head races.

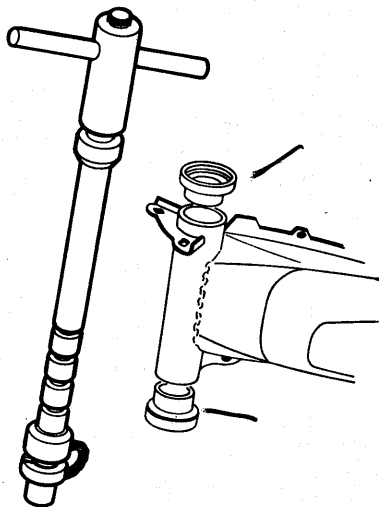

Fig. 1

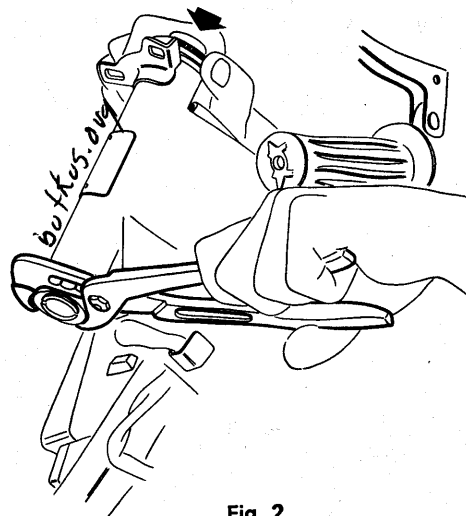

Fig. 2

## REMOVING AND REFITTING THE FRONT AND REAR WHEELS

### REMOVING THE REAR WHEEL:

- Place the machine on the center stand and loosen the rear wheel axle nuts.
- Loosen almost fully the left hand axle nut to remove the chain adjuster bolt. Lift the drive chain off the rear wheel sprocket (fig. 1).
- Push the chain tensioner up into the locked position and lift the pedaling chain off the freewheel (fig. 2).
- Push the cam lever forward to release the rear brake cable (fig. 1).
- Remove the wheel.
- Remove the brake assembly and inspect the brake shoes.

### REFITTING THE REAR WHEEL:

- Reverse the procedure.
- Make sure the slot in the brake backing plate fits over the lug welded on the swing arm (fig. 3).
- Apply the brake and tighten the rear wheel axle nuts. (This will center the brake shoes.)

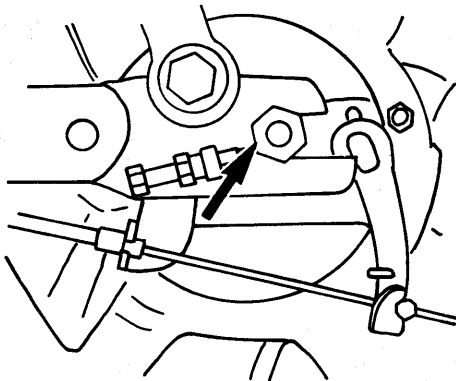

Fig. 1

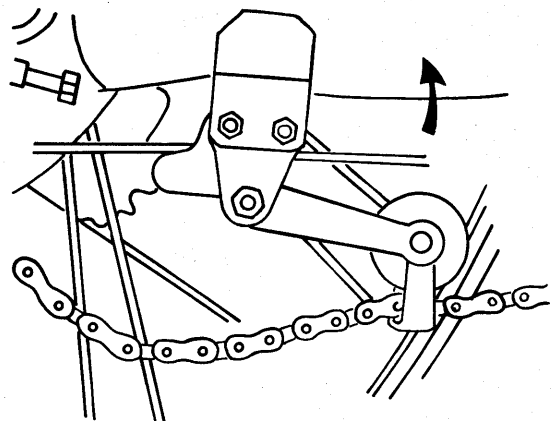

Fig. 2

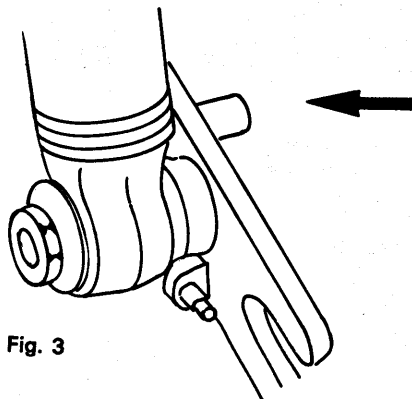

Fig. 3

## REMOVING AND REFITTING THE FRONT AND REAR WHEELS CONT'D.

### REMOVING THE FRONT WHEEL:

- Replace a block under the engine or, if the machine is fitted to a work bench, clamp the rear wheel so that the front wheel is well off the ground.
- Disconnect the speedometer cable and release the front brake cable from the front brake arm (fig. 4).
- Slacken the axle nuts sufficiently enough to free the flat washers (fig. 5).
- Pull the wheel down and out of the fork.
- Remove the brake plate and inspect the brake shoes.
- Clean the drum if necessary.

### REFITTING THE FRONT WHEEL:

- Reverse removal procedure.
- Make sure the lug on the brake backing plate fits into the fork slot (right hand) fig. 6.
- Apply the brake and tighten the front wheel spindle nuts. (This will center the brake shoes.)

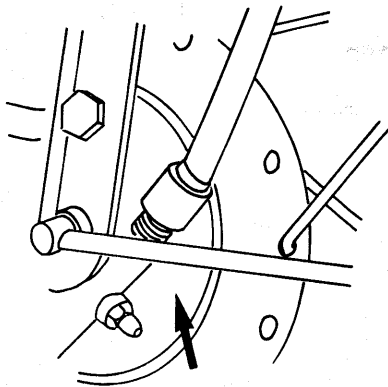

Fig. 4

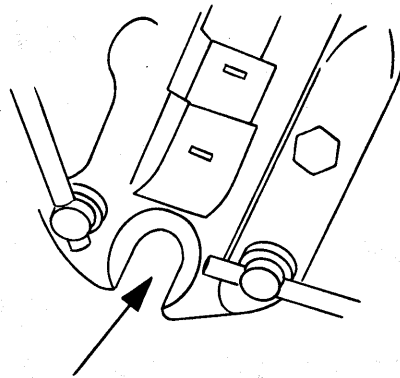

Fig. 5

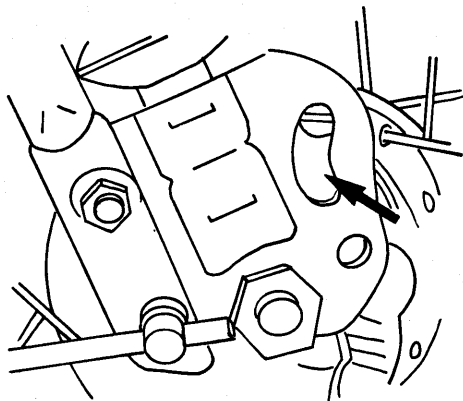

Fig. 6

## REPLACING THE BRAKE SHOES (FRONT OR REAR)

### REMOVING THE BRAKE SHOES:

- Remove the wheel from the chassis (refer to page 66).
- Remove the brake backing plate from the wheel hub.
- Clamp the brake plate in a vice and inspect the brake shoes before removing them from the brake backing plate.
- Insert a screwdriver between the brake backing plate and one brake shoe and press against it to remove the shoe (fig. 1). Lift the other shoe off the backing plate assembly.

NOTE: Be careful not to bend the backing plate when removing the brake shoes.

### REFITTING THE BRAKE SHOES:

- Assemble the new brake shoes with the return springs.
- Force the shoes apart holding them in a "V" formation (fig. 2).
- Press downwards on the brake shoe to position it correctly.
- Coat the brake pivot cam with a light film of grease (fig. 3).
- The inner surfaces of the brake drums must be kept free from oily substances.

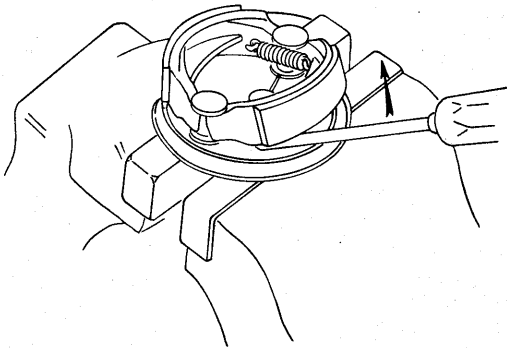

Fig. 1

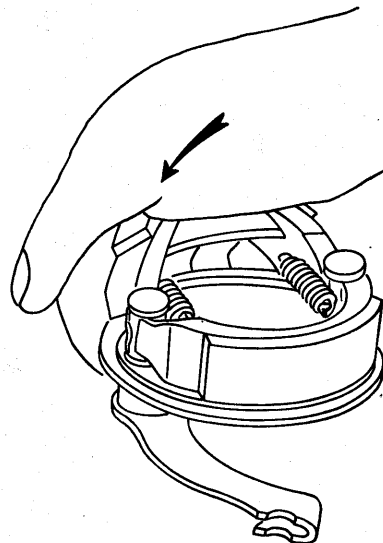

Fig. 2

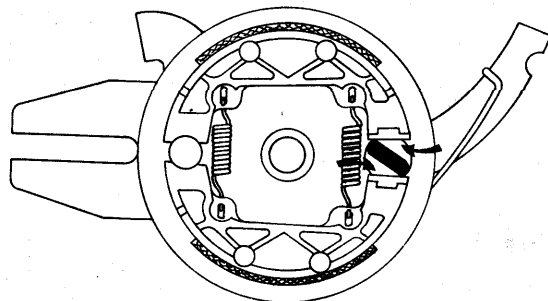

Fig. 3



## REMOVING THE CENTER STAND, THE SADDLE REPLACING THE PEDALLING CHAIN AND THE DRIVE CHAIN

### REMOVING THE CENTER STAND:

- Using multi-lock pliers, grip the crankgear pulley dust cap and remove it. (See page 47).
- Remove the retaining ring using the opening pliers No. 100002. (See page 47).
- Tilt the machine (pulley opposite side).
- Set the center stand spring by passing a piece of string through the lower bow of the spring (fig. 1).
- Remove the spring (fig. 1).
- Remove the nut securing the center stand bolt (13mm socket and 14mm open end wrench).
- Slightly pull the pulley upwards and remove the bolt (fig. 1).
- Remove the other bolt and remove the center stand.

### REFITTING THE CENTER STAND:

- Reverse the procedure.
- If necessary, replace the dust cap on the crankgear pulley.

### REMOVING THE SADDLE:

- Loosen the saddle clamp (13mm socket).
- Lift the saddle upwards and remove it.

### REFITTING THE SADDLE:

- Reverse the procedure.

NOTE: When refitting a saddle, make sure that it does not come to rest on the seat post when sat upon.

### REPLACING THE PEDAL CHAIN:

- Push the chain tensioner up into the locked position.

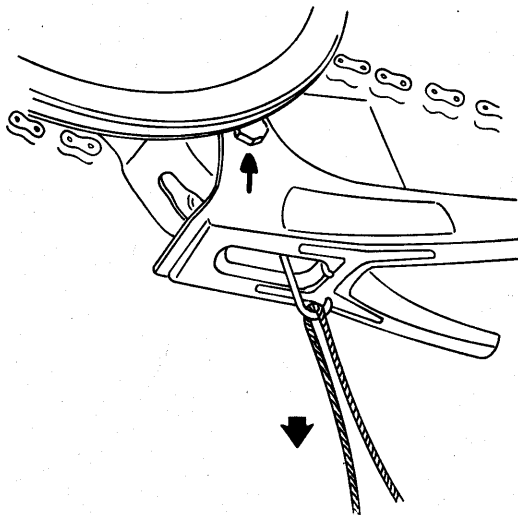

Fig. 1

REMOVING THE CENTER STAND, THE SADDLE  
REPLACING THE PEDALLING CHAIN AND THE DRIVE CHAIN  
CONT'D.

- Remove the joint clip (flat nose pliers). There are two types of pedal chain joint clips (fig. 2 and 3).
- Connect the new chain with the chain joint of the old chain and pull it around the freewheel until the new chain end is brought out.
- Fit the joint clip (flat nose pliers) (fig. 4).
- Release the chain tensioner to bring it back into position.

REPLACING THE DRIVE CHAIN:

- Loosen the rear axle wheel nuts (19mm wrench) and unscrew the adjuster bolts a few turns (8mm wrench).
- Remove the master link clip (flat nose pliers).
- Connect the new chain with the chain link of the old chain and pull it around the sprocket until the new chain end is brought out.
- Fit the link clip (flat nose pliers) (fig. 4).
- Center the wheel (as illustrated on page 75) and adjust the chain tension by means of adjuster bolts (one must take into account the rider's weight).
- Lock the axle nuts (19mm wrench).
- The wheel should turn freely with no roughness or tight spots (arrow - 1cm, fig. 5).

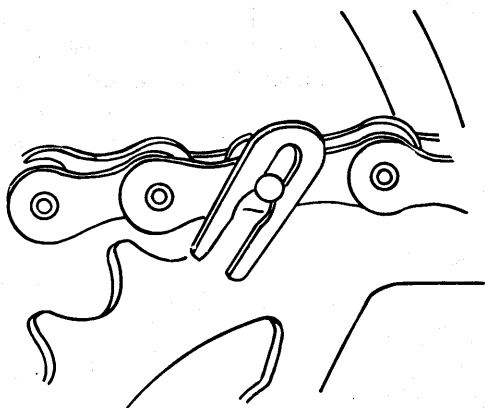

Fig. 2

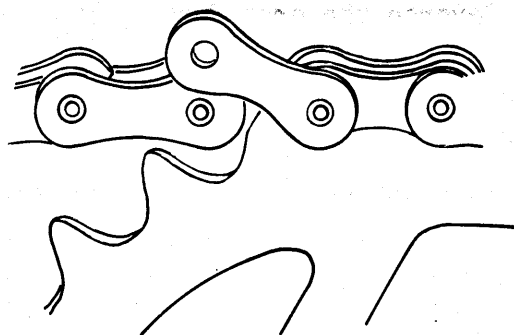

Fig. 3

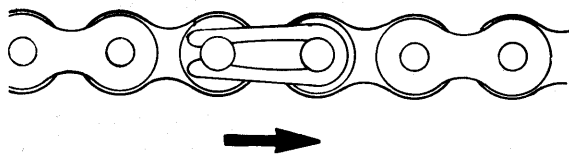

Fig. 4

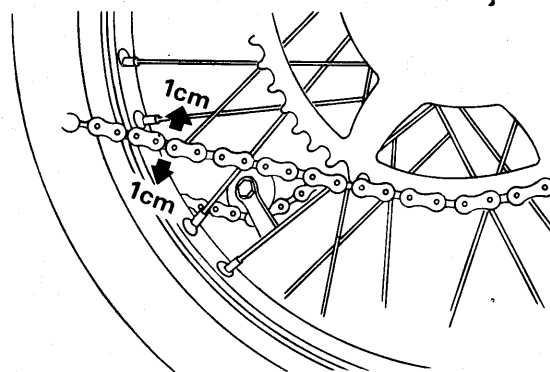

Fig. 5

## REPLACING THE FRONT WHEEL ADJUSTMENT CONES, CUPS, AND BALLS

- Remove the front wheel and the front brake plate (refer to page 67).
- Remove the axle nut on the other side of the wheel (18mm wrench), together with the washers and speedometer drive unit (fig. 1).
- Remove the spacer and the foam washer.
- Remove the cone lock nut (17mm wrench) and keyed washer. Remove the cone (fig. 2).
- Remove the axle nut.
- Remove the two oil deflectors using a screwdriver and take care not to drop the balls, diameter 5.5mm (11 balls on each side, fig. 3).
- Remove the bearing cups using a drift punch and a hammer.

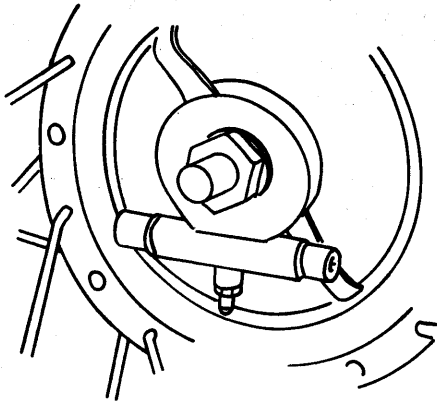

Fig. 1

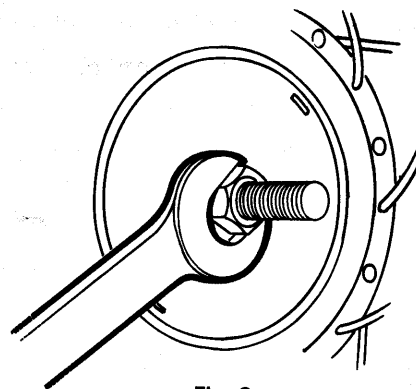

Fig. 2

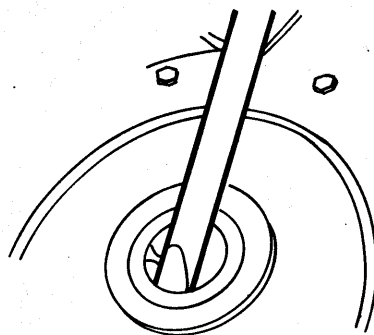

Fig. 3

# REPLACING THE FRONT WHEEL ADJUSTMENT CONES, CUPS, AND BALLS

## CONT'D.

- Install the new hub bearing cups using Tool No. 100014 (tube) and a hammer (fig. 4).
- Make sure the axle is perfectly true. If it is not, fit a replacement one.
- Screw in the new cone on almost 50mm from the axle end.
- Fit the keyed washer and the cone lock nut (17mm wrench).
- Smear the cups with grease, fit the balls on the brake drum side and fit the oil deflector.
- Insert the axle in the nut, fit the other balls and fix the other oil deflector (fig. 5).
- Screw in the cone lock nut and keyed washer. The wheel should turn freely without play.
- Fit the foam washer (replace it if necessary), the spacer, the speedometer drive unit, the washer and the nut without locking it.
- Fit the wheel (refer to page 67).
- Tighten the axle nut on the brake side.
- Connect the speedometer control on the speedometer drive unit and tighten the nut (18mm wrench).
- Lock the axle nuts while applying the brakes.

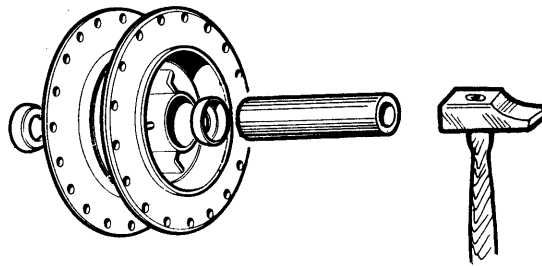

Fig. 4

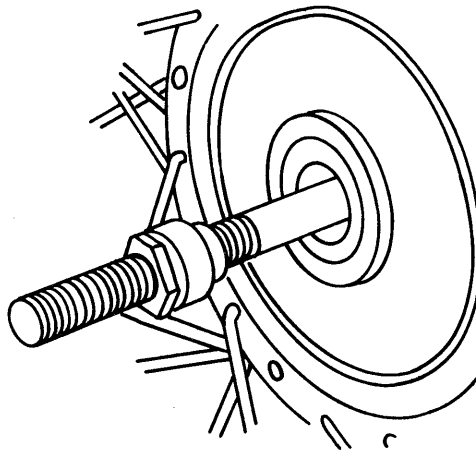

Fig. 5

## REPLACING REAR WHEEL BALL BEARINGS

- Remove the rear wheel and pull out the rear brake assembly (refer to page 66).
- Remove the axle by tapping with a mallet (fig. 1).
- Remove the star washer, the shouldered spacer, and the spacer (freewheel side).
- Remove the bearing locknut with punch and hammer (fig. 2).
- Remove the dust cap on the freewheel side with a screwdriver.
- Insert a drift punch and knock out the bearing (diameter 30mm) on drum side (fig. 3).
- Remove the bearing spacer and pull out the other bearing (diameter 26mm) using a steel tube, diameter 23mm.
- Remove the wheel nut and locknut that remained on the axle (17mm wrench).
- Make sure the axle is true. (Fit a replacement one if it is not.)
- Drive home the new bearing (diameter 30mm) on brake side using a steel tube (diameter 28mm) (fig. 4).

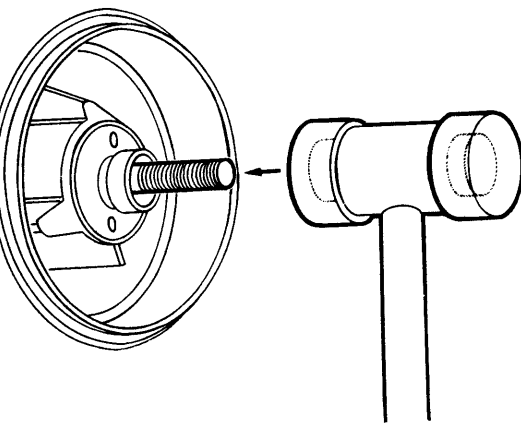

Fig. 1

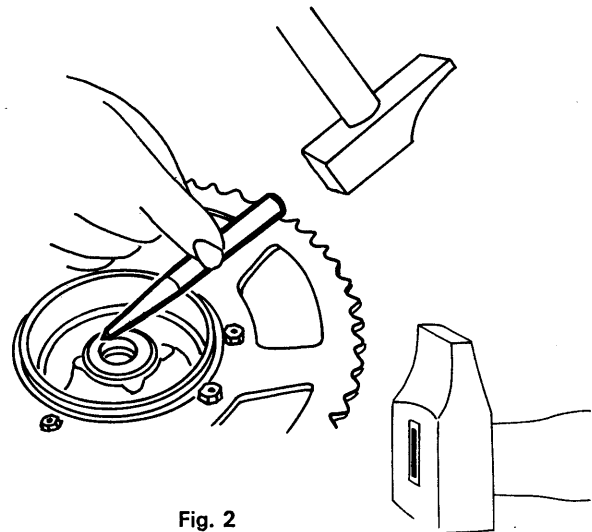

Fig. 2

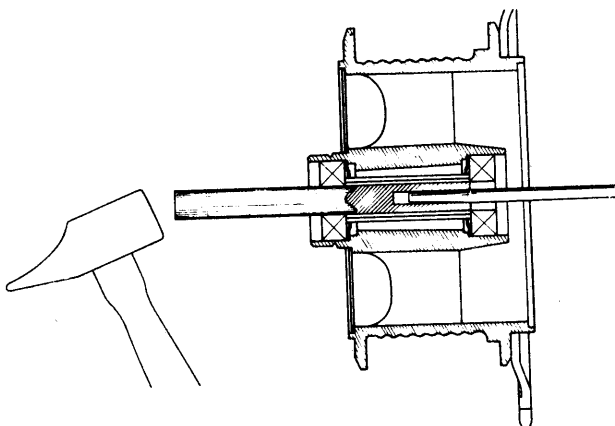

Fig. 3

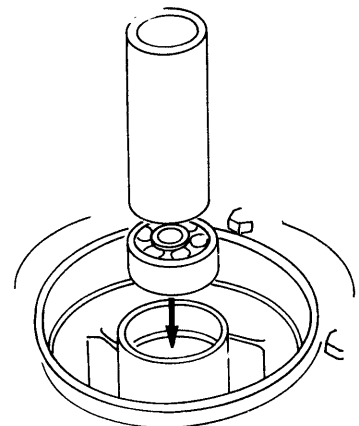

Fig. 4

## REPLACING REAR WHEEL BALL BEARINGS

CONT'D.

### REPLACING THE FREEWHEEL

- Fit the bearing locknut and punch lock it (2 opposite punch marks on thread circumference) (fig. 1).
- Insert the bearing spacer into the hub and insert the 26mm diameter bearing using a 23mm diameter steel tube.
- Make sure that the inner diameter of the bearings and the spacer are aligned.
- Fit the dust cap.

### REFITTING THE AXLE AND THE REAR BRAKE PLATE ASSEMBLY:

- Reverse dismantling procedure.
- Fit the rear wheel (refer to page 66).

### REPLACING THE FREEWHEEL:

- Remove the rear wheel (refer to page 66).
- Remove the freewheel using Tool No. 100022 (fig. 2).
- Reverse the procedure to fit the new freewheel.

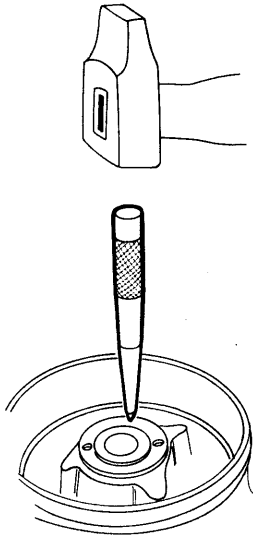

Fig. 1

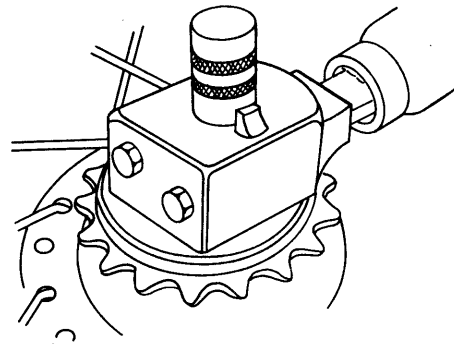
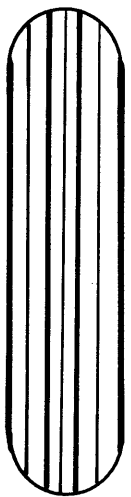

Fig. 2

CHECKING WHEEL ALIGNMENT

TO EFFECT THIS TEST, FACE THE FRONT WHEEL AS OUTLINED BY THE ARROW,



3

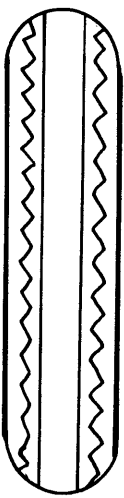

INCORRECT

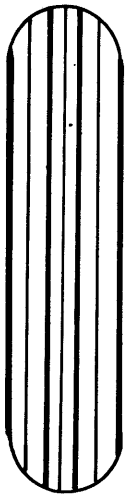

2

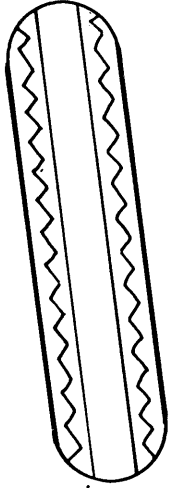

CORRECT

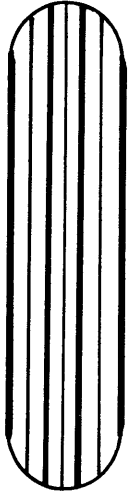

1

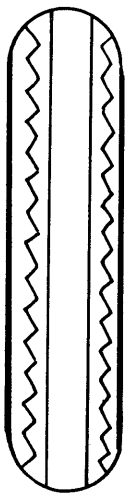

1. Correct alignment.
2. Faulty alignment, necessary to realign the rear wheel.
3. Faulty alignment, no possibility to realign. The fork, frame, or rear swing arm need truing.

## REMOVING AND REFITTING THE FRONT AND REAR FENDERS

### REMOVING THE FRONT FENDER:

- Remove the front wheel (refer to page 67).
- Remove the fender stay fixing bolts and fender bracket bolts (10mm wrench, fig. 1).
- Remove the fender.

### REFITTING THE FRONT FENDER:

- Reverse the procedure.

### REMOVING THE REAR FENDER:

- This removal may be effected without removing the rear wheel (according to the case).
- Remove both side covers (screwdriver).
- Remove the shock absorbers upper mounting bolts (13mm wrench, fig. 2).

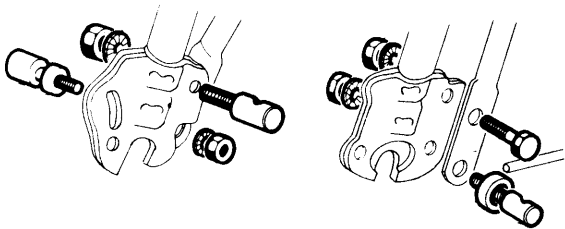

Fig. 1

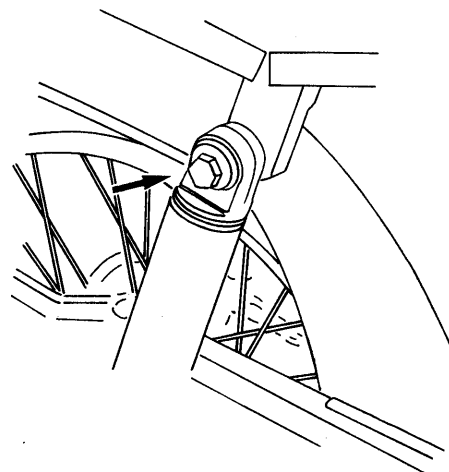

Fig. 2



REMOVING AND REFITTING THE FRONT AND REAR FENDERS  
CONT'D.

- Remove rear fender lower mounting bolts (10mm wrench, fig. 3).
- Remove the bolts securing the luggage carrier rack to the fender (10mm socket and wrench, fig. 4).
- Remove the rear mounting screws (Philips head) of the luggage rack (fig. 4).
- Remove both tool box covers.
- Flatten the antivibration brackets inside the fender.
- Disconnect the rear wiring harness (multi-connector Block) at the lower part of the frame.
- Remove the fender with wiring.

REFITTING THE REAR FENDER:

- Fit on the new fender, the parts left on the old fender: (wiring, supports).
- Reverse the removal procedure.

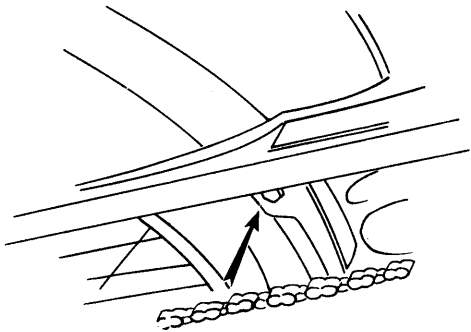

Fig. 3

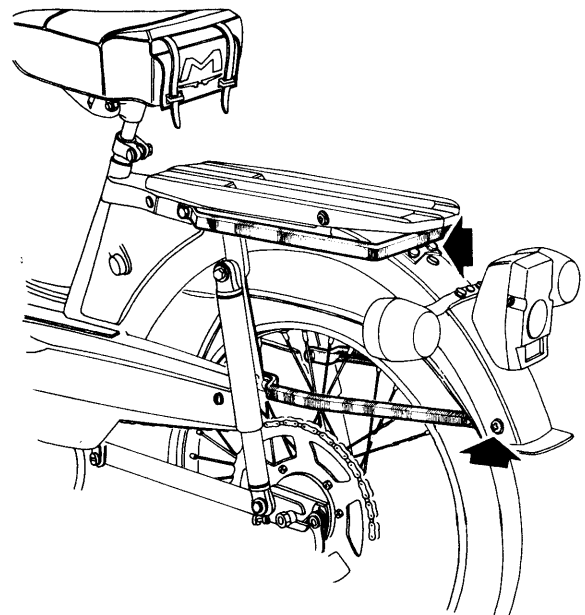

Fig. 4

## REMOVING AND REFITTING THE SHOCK ABSORBERS AND THE SWING ARM

### REMOVING THE SHOCK ABSORBERS:

- Remove the locknut on the shock absorber lower mounting bolt (13mm open wrench, fig. 1).
- Remove the lower mounting bolts (13mm wrench, fig. 2).
- Collect the locknuts, spacers, and washers.
- The wheel and swing arm assembly are now free to drop down.
- Remove the upper bolt assemblies (13mm wrench, fig. 2).
- Remove the shock absorbers.

### REFITTING THE SHOCK ABSORBERS:

- Reverse the above procedure but screw in the right hand lower bolt locknut before screwing the bolt in fully. When the bolt is screwed home, the distance between the bolt and the freewheel prevents locknut fitting.

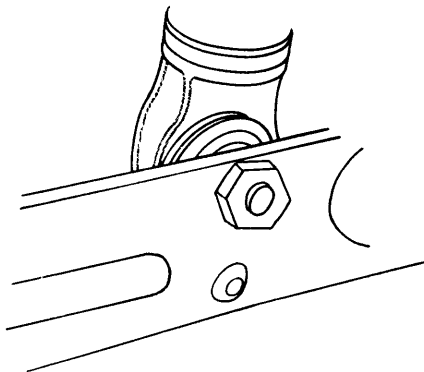

Fig. 1

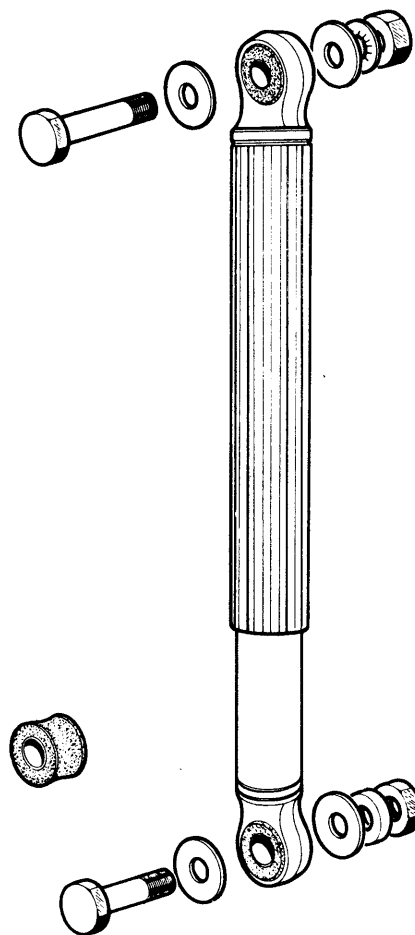

Fig. 2

## REMOVING AND REFITTING THE SHOCK ABSORBERS AND THE SWING ARM CONT'D.

### REMOVING THE SWING ARM:

- Remove the rear wheel (refer to page 66).
- Remove the shock absorber lower mounting bolts (fig. 2).
- Remove the driven pulley (refer to page 47).
- Remove the chain tensioner (8mm socket).
- Remove the swing arm pivot shaft and nut (17mm wrench, fig. 3 and 4).
- Remove the swing arm.

### REFITTING THE SWING ARM:

- Position the swing arm and insert the pivot bolt.
- Screw in the nut without locking it.
- Fit the chain tensioner (8mm wrench).
- Fit the chains (bicycle and engine) through the swing arm.
- Fit the shock absorber lower mounting bolts with lock nuts (13mm wrench).
- Lock the nut securing the swing arm pivot shaft (17mm wrench).
- Fit the driven pulley (refer to page 48).
- Fit the rear wheel (refer to page 66).

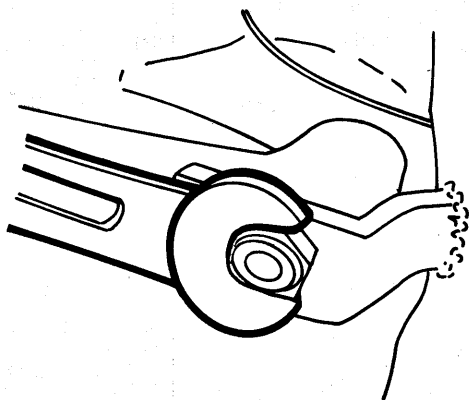

Fig. 3

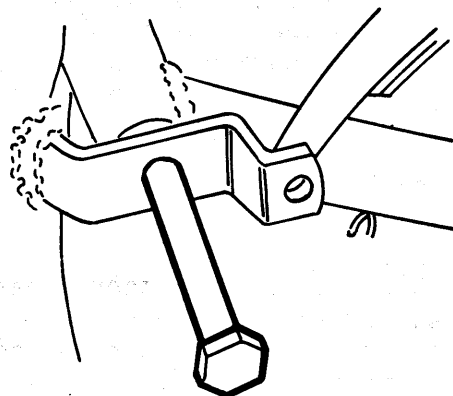

Fig. 4

## MOTOBECANE TROUBLE SHOOTING GUIDE

The following guide is designed to reduce the amount of time spent trouble shooting a service problem. When reading through the trouble shooting guide, some of the steps will be referenced with the symbol (6V). This notation refers to machines manufactured by Motobecane prior to January 1, 1978, and which are equipped with a six \*(6) volt lighting system. Subsequently, all Motobecane Mopeds manufactured for the United States after January 1, 1978, are equipped with a 12 volt lighting system.

### HELPFUL HINTS:

1. When trouble shooting electrical components, the quickest and easiest method is substitution.
  - A) Make sure that the part being used in the substitution is known to be good.
  - B) When a parts substitution is made and the problem is not solved, leave the newly substituted part in the system until the problem is found. Then, back track one component at a time. This method will enable you to more effectively trouble shoot a machine which may have multiple problems.

## ENGINE

### I. ENGINE WILL NOT START

- A) Check for spark at spark plug.
- B) Check for flow restrictions in the fuel system.
- C) Check engine compression by turning the clutch drum by hand with the spark plug installed.
- D) Check to see if the engine stop switch is in the "run" position.

### II. NO SPARK

- A) Faulty spark plug
- B) Faulty radio suppressor (spark plug cover)
- C) Faulty high tension coil
- D) Faulty ignition points and condenser
- E) Ignition points not opening
- F) Grounding wire inside the magneto
- G) Magneto wiring harness burnt or broken behind the engine
- H) Poor magnetism present in rotor
- I) Faulty exciter coil inside magneto
- J) Black wire from magneto broken or disconnected \*(6V)

## MOTOBECANE TROUBLE SHOOTING GUIDE

### ENGINE, CONT'D.

#### III. GOOD IGNITION SPARK, BUT THE ENGINE WILL NOT START

- A) Decompression valve cable adjusted too tight
- B) Restriction of fuel flow (Ex. fuel tap, fuel tank, fuel line, carburetor)
- C) Faulty head gasket
- D) Ignition timing incorrectly set
- E) Faulty inlet pipe gasket
- F) Exhaust port and exhaust pipe clogged

#### IV. ENGINE RUNS, BUT HAS A HIGH SPEED MISS

- A) Faulty or worn spark plug
- B) Improper ignition timing
- C) Faulty radio suppressor
- D) Faulty high tension coil
- E) Faulty or worn ignition points and condenser
- F) Faulty head gasket
- G) Decompression valve cable adjusted too tightly
- H) Air leak between inlet pipe and cylinder
- I) Exhaust system clogged

#### V. ENGINE RUNS, BUT HAS LOW SPEED MISS

- A) Improper spark plug
- B) Improper ignition timing
- C) Faulty or worn out ignition points and condenser
- D) Faulty radio suppressor (spark plug cover)
- E) Magneto rotor rubbing on internal coils

#### VI. ENGINE POPS AND BACKFIRES WHEN TRYING TO START

- A) Ignition timing improperly set
- B) Decompression cable adjusted too tight
- C) Faulty cylinder head gasket
- D) Faulty ignition points or condenser

#### VII. DIFFICULT TO START WHEN COLD

- A) Carburetor choke valve not functioning sufficiently
- B) Improper ignition timing

#### VIII. DIFFICULT TO START WHEN WARM

- A) Improper ignition timing
- B) Worn out spark plug
- C) Exhaust system clogged
- D) Faulty ignition points and condenser

MOTOBECANE TROUBLE SHOOTING GUIDE  
ENGINE, CONT'D.

IX. EXCESSIVE FUEL CONSUMPTION

- A) Engine is not broken in (600 miles)
- B) Carburetor choke valve partially opened at all times
- C) Carburetor flooding (sticky float)
- D) Leakage in fuel line

X. ENGINE HAS NO POWER

- A) Improper ignition timing
- B) Clogged exhaust port or pipe
- C) Decompression cable adjusted too tight
- D) Fuel restriction
- E) Worn out piston rings or engine seals
- F) Engine partially seized
- G) Moped chains adjusted too tight
- H) Brakes adjusted too tight

XI. THE ENGINE WILL RUN ONLY IF THE CHOKE IS USED

- A) Clogged fuel jet in carburetor
- B) Clogged fuel line
- C) Clogged fuel filter in carburetor or gas tank
- D) Clogged filter cap vent hole
- E) Loose or cracked inlet pipe and gasket
- F) Loose carburetor

XII. ENGINE WILL RUN BUT WON'T IDLE

- A) Idle circuit in carburetor clogged
- B) Throttle slide facing wrong direction in carburetor
- C) Idle screw not adjusted correctly
- D) Air leak at carburetor or inlet pipe mounts

XIII. ENGINE SEIZED OR STARTS KNOCKING

- A) Insufficient oil in fuel mixture
- B) Connecting rod looseness on crankshaft
- C) Loose magnet in flywheel
- D) Loose flywheel jammed on stator plate
- E) Piston seized to cylinder

## POOR ENGINE PERFORMANCE

Very often poor engine performance may not be related to the engine itself, but to one or several frequently unsuspected secondary causes.

In such a case, we suggest the following:

1. Check that the decompressor control is not or has not been overadjusted which might damage the valve and entail compression loss (this is a frequent cause).
2. Check that the throttle slide opens fully. Quite often the control is badly adjusted and the engine is starved even at full throttle position.
3. Check that there is no braking action due to chains being too tight. In this respect, on Mobylettes fitted with a swing arm rear suspension, tension adjustment must be performed in the running position, the machine loaded with a rider weighing about 165 lbs.
4. Check variator operation.
5. Make sure the belt is correctly aligned.
6. Make sure the brakes are not adjusted too tightly.
7. Check that the fuel cap vent hole is not clogged as this may bring about poor fuel supply.
8. Check that the spark plug is in accordance with the manufacturer's specifications.
9. Check that the exhaust is neither partially blocked nor blocked. If this is the case, clean out the complete exhaust system.
10. Very important note: Quite often poor engine performance may be caused by overtightening the cylinder head nuts and thereby distorting the cylinder. (Cylinder head nut torque is 9 lbs. ft.)

## LIGHTING CIRCUIT

### I. NO LIGHTS AT ALL

- A) Faulty zener diode \*(6V)
- B) Faulty headlamp switch
- C) Faulty lighting coil or coil ground
- D) Magneto harness burnt or grounding behind engine
- E) Wiring harness connector block disconnected behind carburetor
- F) Improper wire connections
- G) Blown bulbs

MOTOBECANE TROUBLE SHOOTING GUIDE  
LIGHTING CIRCUIT, CONT'D.

II. NO BRAKE LIGHTS

- A) Faulty brake light switch
- B) Faulty ground at rear fender
- C) Faulty stop light coil or ground (if equipped with 12V system)

III. DIM LIGHTS AND NO HORN WHEN HEADLAMP SWITCH IS ON

- A) Faulty zener diode \*(6V)
- B) Faulty lighting coil
- C) Faulty brown wire or connection
- D) Incorrect bulbs

IV. EXCESSIVE LIGHT CAUSING LAMP BURNOUT

- A) Faulty zener diode \*(6V)
- B) Incorrect bulbs

V. NO HORN

- A) Faulty zener diode \*(6V)
- B) Faulty horn unit
- C) Faulty horn switch
- D) Faulty horn wires or connections

VI. WHEN LIGHTS ARE TURNED ON, THE ENGINE STALLS \*(6V)

- A) Faulty zener diode \*(6V)
- B) Faulty headlamp switch \*(6V)
- C) Faulty brake light switches \*(6V)
- D) Faulty black wire or connection in magneto harness \*(6V)



12 VOLT SYSTEM  
 (MACHINES MANUFACTURED AFTER JANUARY 1, 1978)

R.H. STOP LIGHT SWITCH

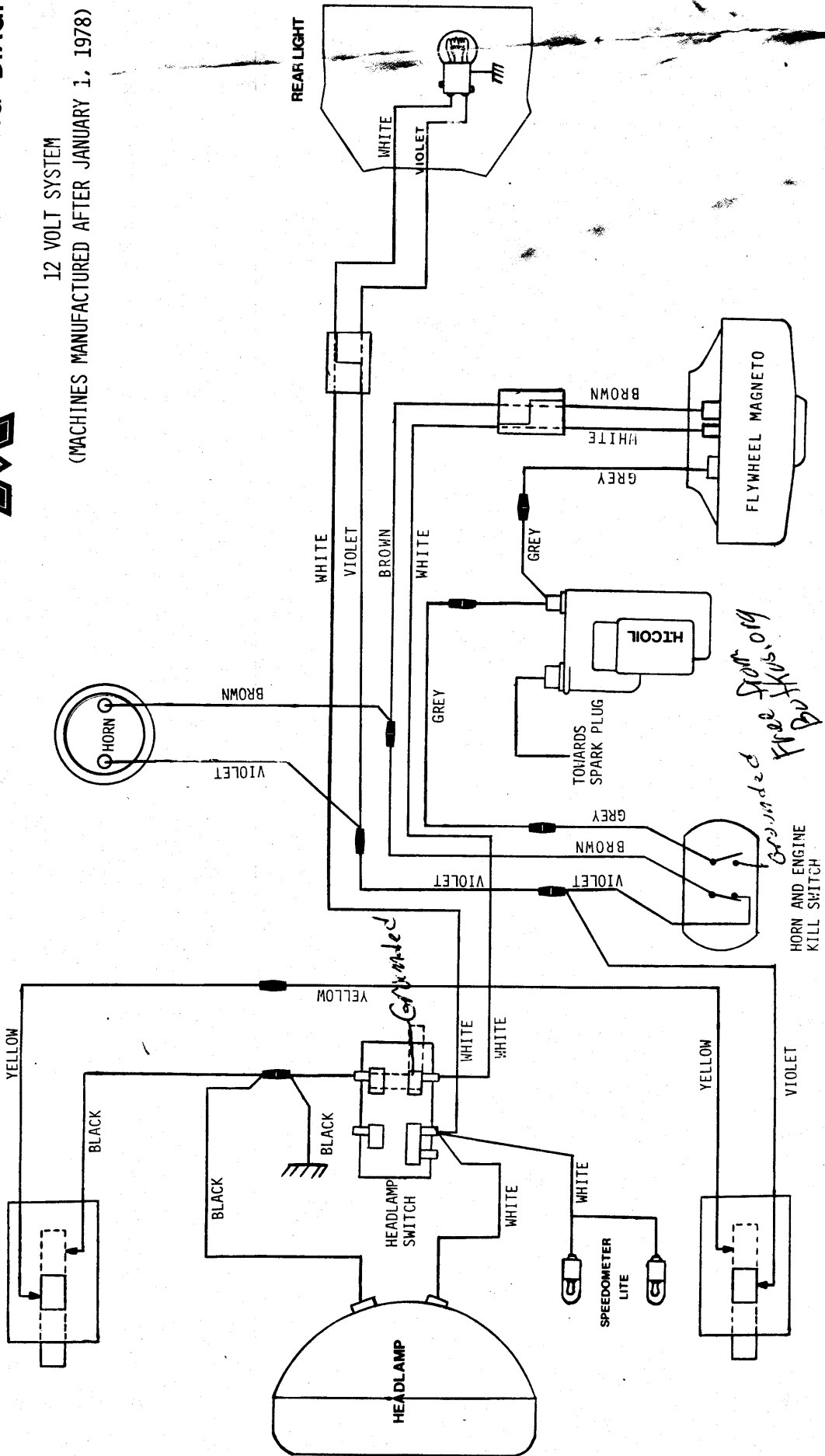

L.H. STOP LIGHT SWITCH

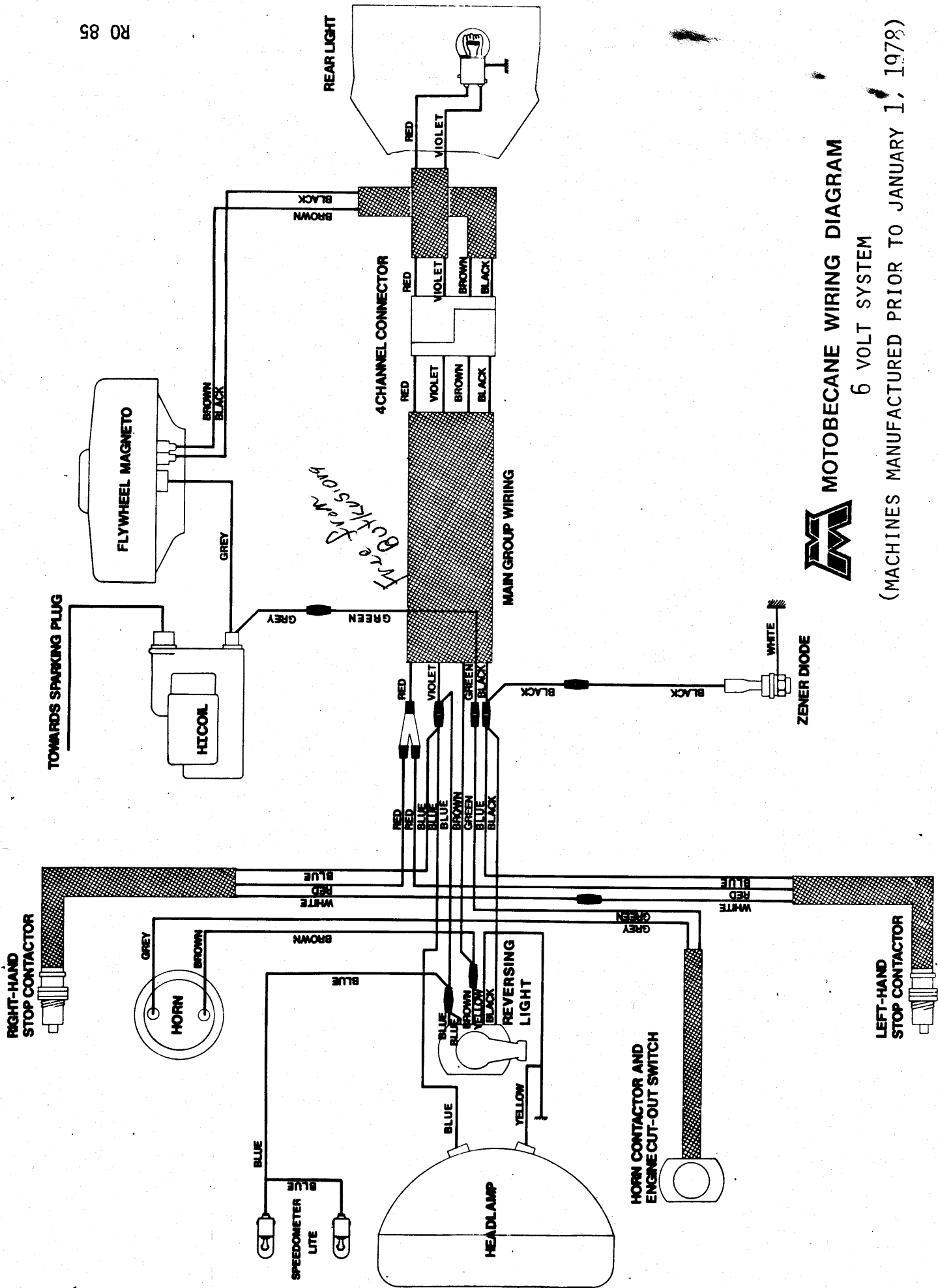

MOTOBECANE WIRING DIAGRAM

6 VOLT SYSTEM

(MACHINES MANUFACTURED PRIOR TO JANUARY 1, 1978)