

# Ricoh KR-5

- similar to Sears KS-500 and CR-5 -  
**35mm camera manual**

This camera manual library is for reference and historical purposes, all rights reserved.

This page is copyright by [mike@butkus.org](mailto:mike@butkus.org), M. Butkus, N.J.

This page may not be sold or distributed without the expressed permission of the producer

This is the full text and images from the manual.

[Back to my main Chinon page](#)

If you find this manual useful, how about a donation of \$3 to:

**M. Butkus, 29 Lake Ave., High Bridge, NJ 08829 T**

**his will allow me to continue to buy new manuals and pay their shipping costs.**

**It'll make you feel better, won't it?**

**If you use Pay Pal, use the link below. Use the above address for a check, M.O. or cash.**

Venmo is @mike-butkus-camera



[www.PayPal.me/butkus](http://www.PayPal.me/butkus)

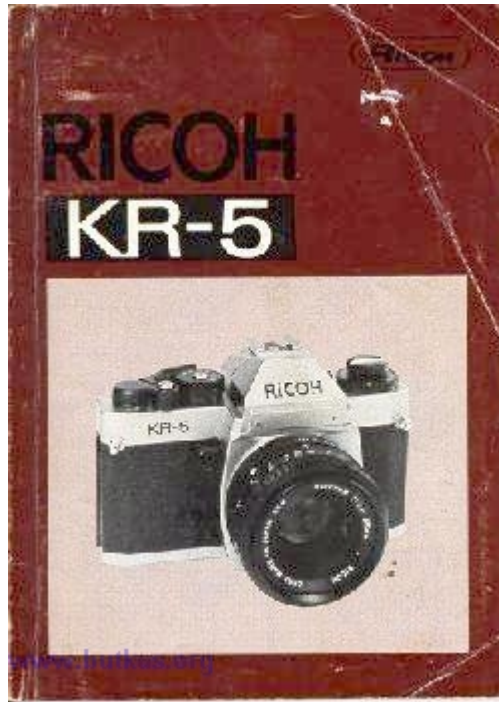

### 3. Film Speed Dial (ASA/DIN)

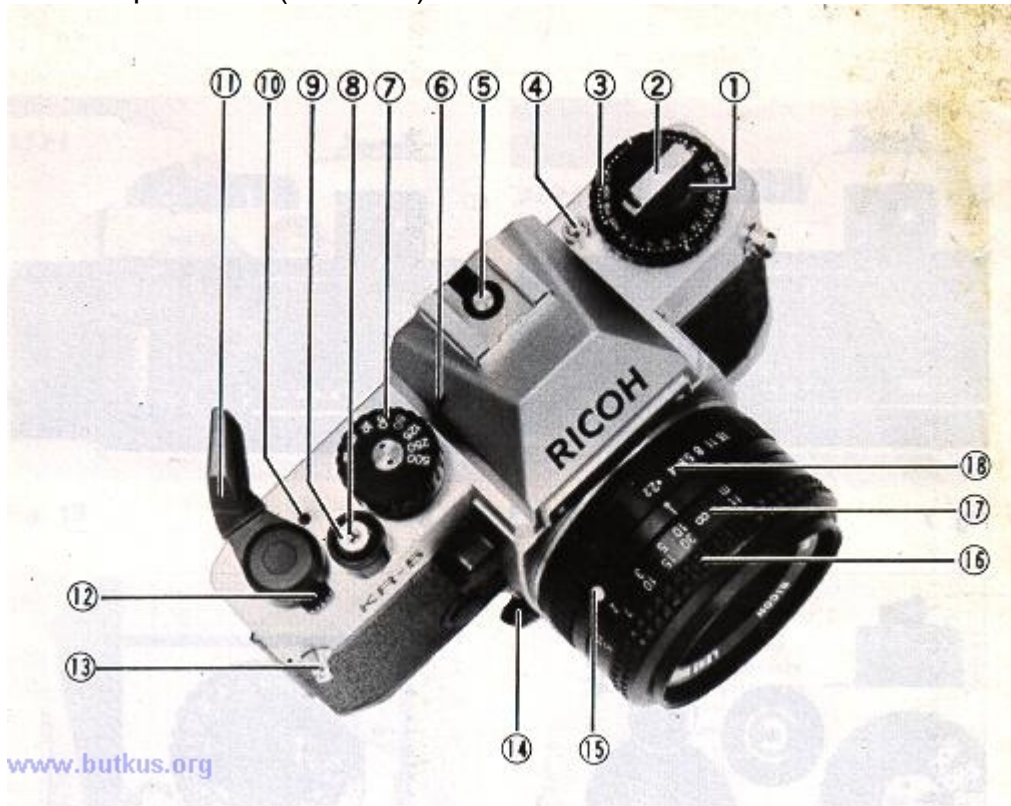

#### DESCRIPTION OF PARTS

1. Film Rewind Knob/Back Cover Lock Release Knob
2. Film Rewind Crank
4. Film Speed Lock Button
5. Hot Shoe/Flash Contact
6. Shutter Speed Index Line
7. Shutter Speed Dial
8. Cable Release Socket
9. Shutter Release Button
10. Meter/Shutter "ON-OFF" Index Mark

11. Film Advance Lever
12. Exposure Counter
13. Neck Strap Eyelet
14. Lens Release Lever
15. Lens Locator Node
16. Focusing Ring
17. Distance Scale

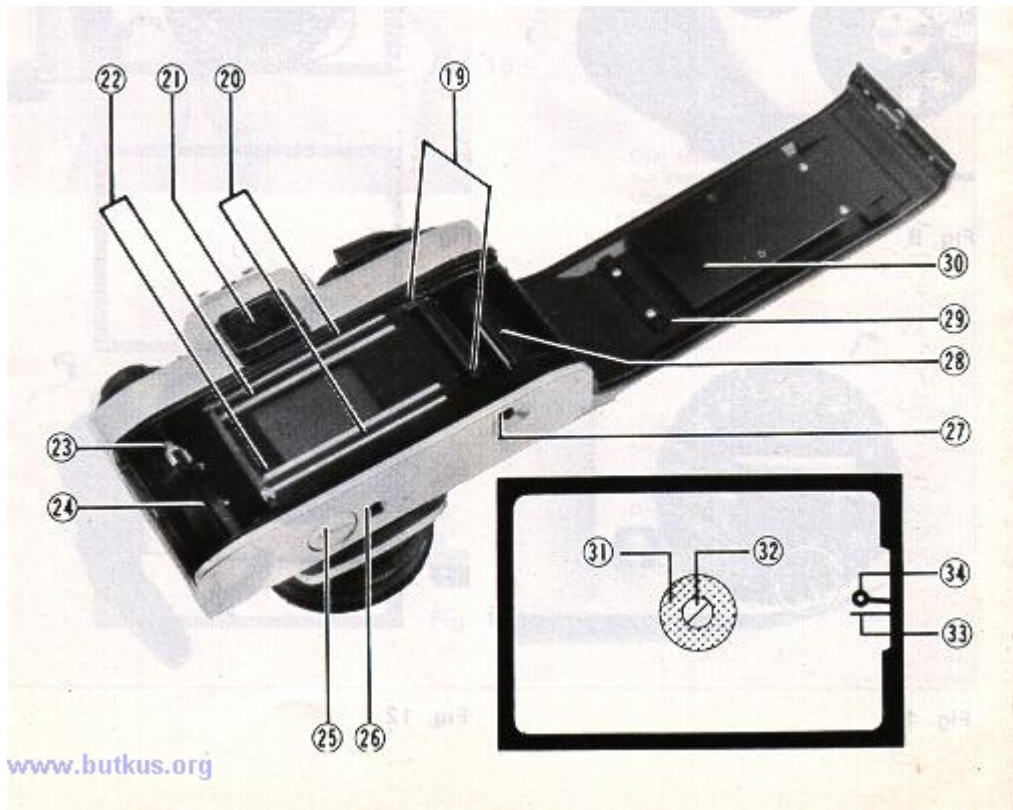

18. F-Stop Ring

19. Sprocket Teeth

20. Film Guide Rail

21. Viewfinder Eyepiece

22. Film Rail

23. Film Rewind Shaft

24. Film Chamber

25. Battery Compartment Cover

26. Tripod Socket

27. Film Rewind Release Button

28. Film Take-up Spool

29. Back Cover

30. Film Pressure Plate

31. Microprism image Band

32. Split-image Spot

33. Exposure Meter Needle

34 Shutter Speed Needle

We are most gratified that you have selected the KR-5 which we are sure will give you many delightful years of picture-taking pleasure. The KR-5 is a 35 mm SLR camera which assures you superb optics and outstanding mechanical performance and reliability and which will justify your choice for years to come.

### **Before Using Your KR-5 .....**

Please read this instruction booklet carefully and familiarize yourself with the equipment and its features thoroughly. Your pleasure in using your KR-5 will be greater if you know your camera properly...

### **BATTERY LOADING**

The built-in through-the-lens CdS exposure metering system of you' KR-5 operates on power activated by two 1.5V G13 silver-oxide batteries. which are supplied together with your camera.

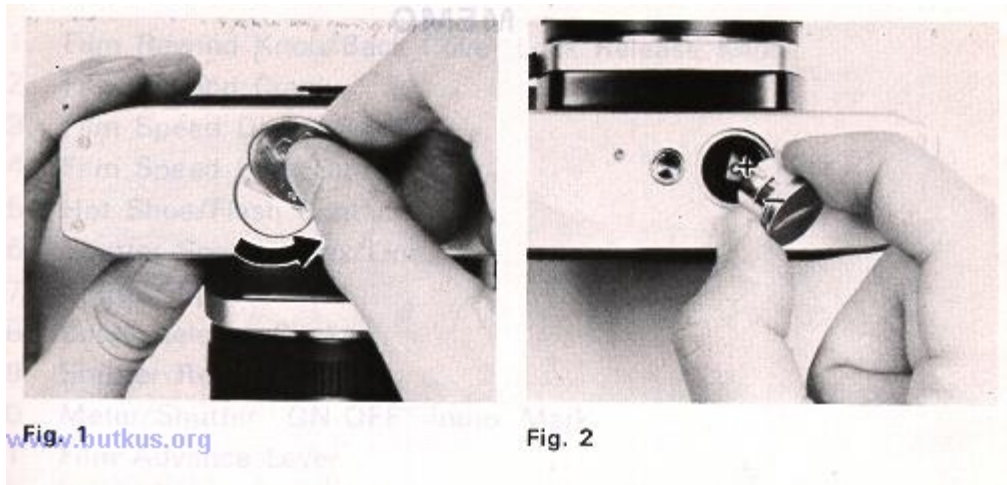

1 Remove Battery Compartment Cover (25) by unscrewing it, counterclockwise with a coin (Fig. 1).

2. Place the two batteries into the compartment with the plus ( + ) side down as illustrated in the battery holder of Battery Compartment Cover (25) (Fig. 2) Make sure that the batteries are correctly placed. If incorrectly placed, Exposure Meter Needle (33) in the viewfinder will not move at all.

3. Replace Battery Compartment Cover (25) by screwing it clockwise until it stops but do not force

### **Tips for Better Results**

\* Before loading, wipe off the surfaces of the batteries with a clean and dry cloth to ensure they are free of fingerprints or stains.

\* When your camera is not used for a long period, remove the batteries and keep them in a cool, dry place.

\* The batteries will last for about one year in normal use. We suggest you replace them regularly once a year on your birthday or sooner

\* The batteries may explode if disposed of in fire...

\* Replace the batteries when the Exposure Meter Needle (33) in the viewfinder does not move in direct sunlight or other bright lights with Film Advance Lever ( 11 ) moved to "ON" position (Refer to "METER/SHUTTER ON-OFF CONTROL"). For replacement, use two new Mallory MS76, Eveready S76 or equivalent.

## FILM LOADING

Your KR-5 is designed to accept any standard 35 mm color or black and white film roll in cartridge (12, 20, 24 or 36 exposures).

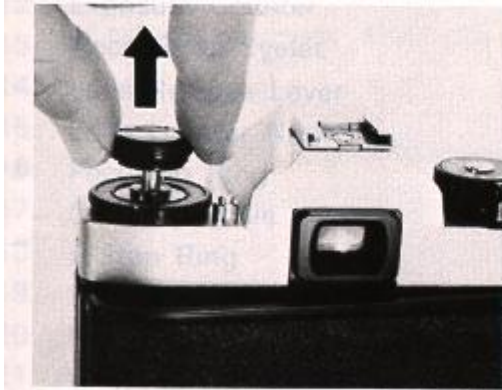

Fig. 3

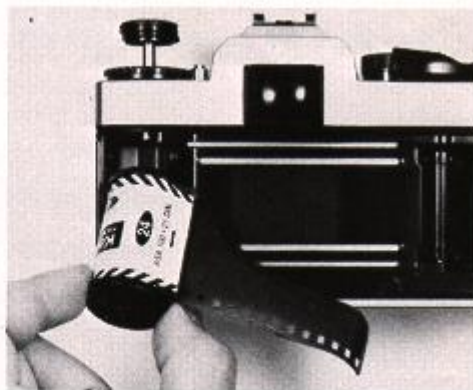

Fig. 4

1. First of all, press Shutter Release Button (9) to see that the shutter has been released. (Refer to "METER" / SHUTTER ON OFF CONTROL")
2. Pull up Film Rewind Knob (1) until Back Cover (29) snaps open (Fig. 3). Then, pull it out all the way to allow for insertion of the film cartridge.
3. Swing open Back Cover (29) and place a film cartridge into Film Chamber (24) (Fig. 4).
4. Push down Film Rewind Knob ( 1 ) to its original position by turning Film Rewind Crank (2) clockwise or counterclockwise so that Film Rewind Shaft (23) engages the film cartridge and that the film cartridge is seated in place (Fig. 5).

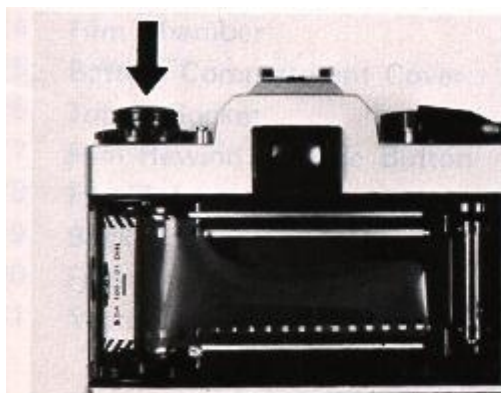

Fig. 5  
[www.butkus.org](http://www.butkus.org)

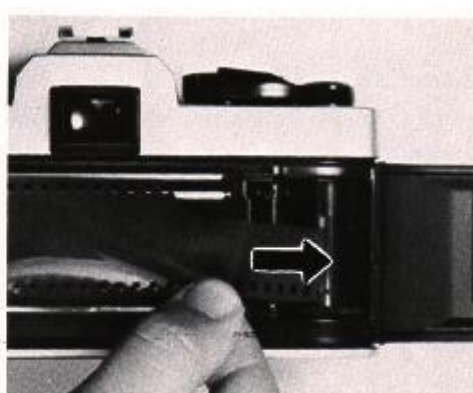

Fig. 6

5. Draw the film leader across the camera back and insert it into one of the slits of Film Take-up Spool (28) (Fig. 6). To bring the slit into a convenient position, rotate Film Take-up Spool (28) in the direction of arrow with your finger.

6. Rotate Film Take-up Spool (28) by advancing Film Advance Lever ( 11 ) to take up any slack in the film and check to see that the film tip is firmly hooked onto Film Take-up Spool (28) (Fig. 7) and that sprocket holes on the film are fully engaged on Sprocket Teeth (19) (Fig. 8).

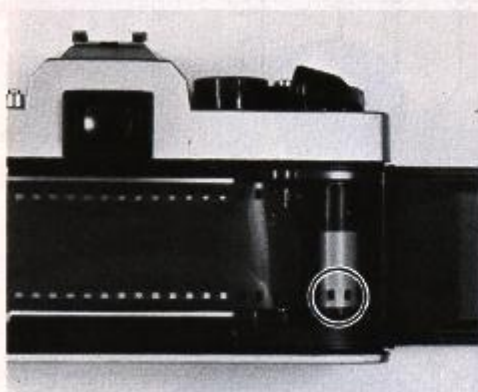

Fig. 7

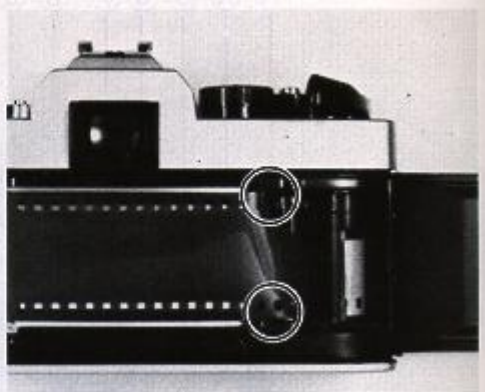

Fig. 8

7. Close and press Back Cover (29) firmly until it snaps shut.

8. Advance Film Advance Lever ( 11 ) two or three times, after depressing Shutter Release Button (9) each time, until the number " 1 " is opposite the index line in Exposure Counter (12) (Fig. 9). because the first portions of the film cannot be used for picture taking as they have already been exposed to light and two or three blank exposures should be made before taking your first picture. Now it is ready for your first picture.

**(Webmaster: Warning, this camera, as many of this type, will continue to advance the numbers even if the film is not loaded correctly. Always make sure the rewind knob turns as the film is advanced those first few time and at other times)**

### Tips for Better Results

\* Always load your camera in the shade or in a poorly-lit place never in direct sunlight or other bright light.

\* As you advance Film Advance Lever (11), Film Rewind Knob (1) will simultaneously rotate counterclockwise indicating that the film is properly advanced.

### SETTING FILM SPEED

Each type of film, color or black and white, has its own sensitivity to light. This sensitivity is assigned by a numerical value described as a ' ASA rating (U.S.A. Standard) or a DIN rating (Europe and most other countries). In most cases, both ASA and DIN ratings are imprints/ on the film package, as well as the data sheet packed with the film and film cartridge itself.

The higher the film speed rating, the more sensitive the film is to light; that is less light is required for a proper exposure. The film speed, therefore, is an important element in insuring that the through-the-lens metering system of your camera; determines the correct shutter speed and f-stop combinations for; given lighting situation.



Fig. 9

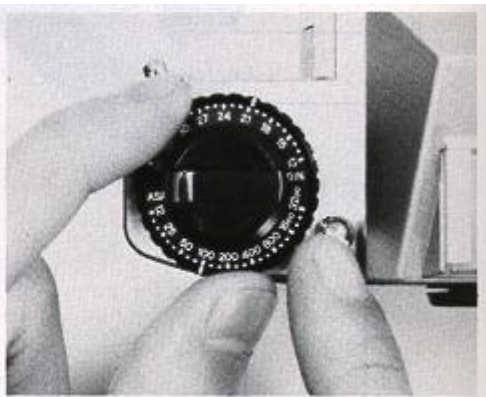

Fig. 10

1. Depress Film Speed Lock Button (4) (Fig. 10) and rotate the outer ring of Film Speed Dial (3) until the ASA (or DIN) number of your film is exactly opposite the index line on the outer ring of Film Speed Dial (3) and click stops. For example, if the film is ASA 100, make the correct setting at "100" (Fig. 11).

2. Take your finger off Film Speed Lock Button (4) to lock the film speed setting in the camera.

### Tips for Better Results

\* Each time a film with a new film speed rating is loaded in you camera. the film speed must be set to assure accurately exposed photographs.

### METER/SHUTTER "ON-OFF" CONTROL

Film Advance Lever (11) controls exposure meter "ON-OFF" and shutter release "LOCK-UNLOCK" to protect your camera from unnecessary depletion of the batteries and accidental shutter release when not taking pictures. 40° pre-advance and 135° advance angle assures faster winding and permits continuous operation for sequence photography.

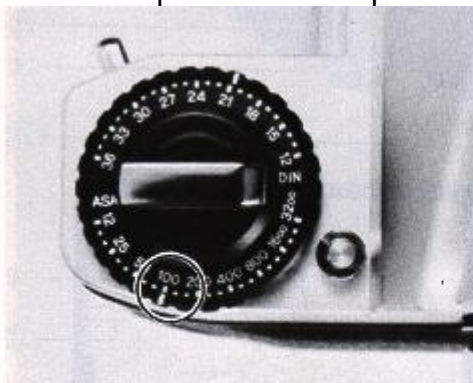

Fig. 11  
[www.butkus.org](http://www.butkus.org)



Fig. 12

1 When Film Advance Lever (11 ) is moved to "ON" position (Fig. 12). the electric circuit is switched on and Shutter Release Button (9) is unlocked.

Whenever picture-taking is completed be sure to move Film Advance Lever ( 11 ) to "OFF" position (Fig. 13) The electric circuit is switched off and Shutter Release Button (9) is locked.

### Tips for Better Results

\* To prevent unnecessary consumption of the batteries. be sure to move Film Advance Lever ( 11 ) to "OFF" position when not taking pictures

### CORRECT EXPOSURE

Your KR-5 has a built-in through-the-lens full aperture CdS exposure meter which measures the light coming through the lens and enables you to set the proper exposure for a given lighting condition. The correct exposure is obtained by setting the shutter speed and f-stop in the correct combination for the film, subject and lighting conditions.

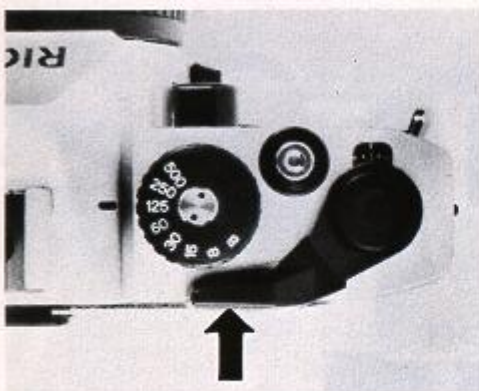

Fig. 13

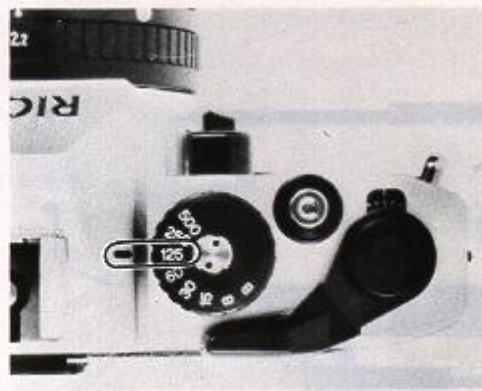

Fig. 14

1 Set the desired shutter speed opposite Shutter Speed Index Line (6) by rotating Shutter Speed Dial (7) (Fig. 14). (Read "SETTING THE SHUTTER") Shutter Speed Needle (35) in the viewfinder moves according to the shutter speed you set.

2. Move Film Advance Lever (11) to "ON" position (Fig. 12)

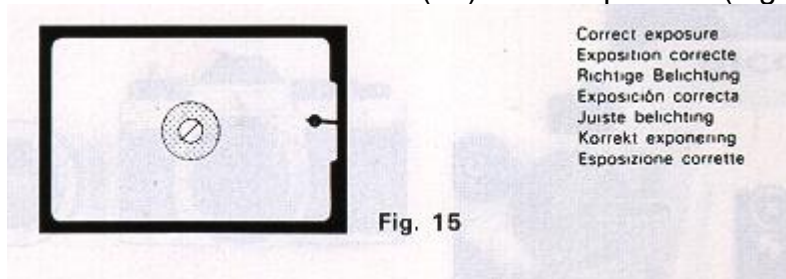
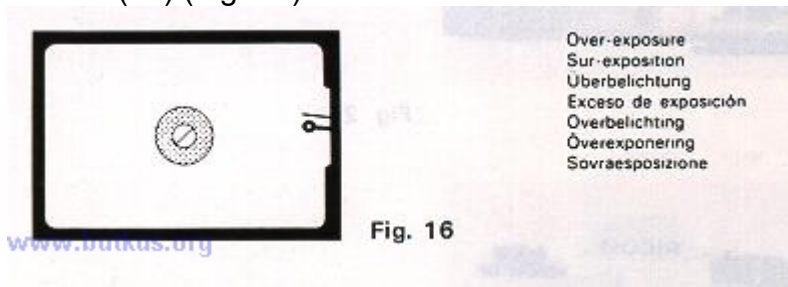

Fig. 15

3. Hold your camera. look at your subject through the Viewfinder Eyepiece (21) and check Exposure Meter Needle (33).



4. Rotate F-Stop (lens opening) Ring (18) and align Exposure Met/ Needle (33) with Shutter Speed Needle (34) (Fig. 15).\_\_



If Exposure Meter Needle (33) goes above Shutter Speed Needle (34). this means "overexposure" (Fig. 16); select a faster shutter speed or a smaller lens opening.

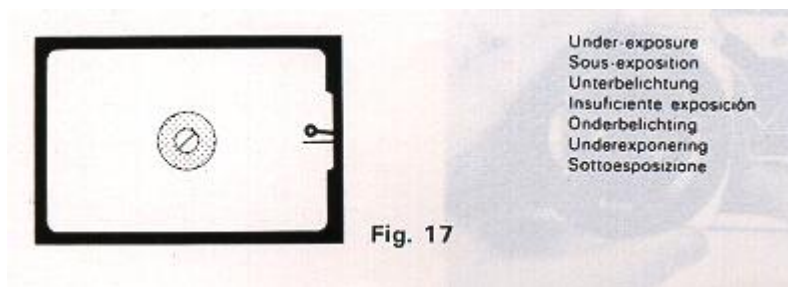

On the contrary. if the needle goes below Shutter Speed Needle (34). this means "under exposure" (Fig 17): choose a slower shutter speed or larger lens opening

If you want to use a specific f-stop for depth of field control, you may set the f-stop first and then the shutter speed. while other procedures are the same as above.

This setting may be used when you take a portrait or the like, intentionally making your subject attractive with the background or the scene in front of it blurred. How your subject turns out in the picture depends on the f-stop setting. (Refer to "DEPTH OF FIELD"). The chart (Fig 18) shows the exposure value range (shutter speed and f-stop combination) of your camera's metering system for selected film speeds

### Exposure Compensation

Though you learned how correct exposure is obtained, in unusual, lighting conditions, the desired effect or the correct exposure will not be obtained in the final picture and exposure compensation is necessary

**Back-lit subjects** When the light is behind the subjects,

1. Move close to the subject for meter reading. then. move back, focus and shoot.
2. If it is impossible to approach the subject, adjust either shutter speed or lens opening to overexpose. When you adjust the lens opening, open up the aperture by 1 or 2 stops.

## Spot-lighted subjects and dark backgrounds

1. Move close to the subject for meter reading. then. move back, focus and shoot.
2. If it is impossible to approach the subject, adjust either shutter speed or lens opening to underexpose. When you adjust the lens opening. close down the aperture by 1 or 2 stops.

### Tips for Better Results

- \* When the Shutter Speed Dial (7) is set at "B" (Bulb), set the desired f-stop and expose manually because metering with the built-in exposure meter is not possible.
- \* Outside of the meter's coupling range, the exposure meter will not respond correctly. For example, coupling range for ASA 100 film is from 1/8 sec. at f/2.2 to 1/500 sec. at f/ 16 (EV 5.3 - 17) (Fig. 18). If the light is too dim, use supplementary lighting.

## SETTING SHUTTER SPEED

The shutter controls the length of time the light is allowed to strike the film. The speed at which the shutter opens and closes is measured in fractions of a second that correspond to the numbers on Shutter Speed Dial (7). For example. "500" is 1/500 sec., "125" is 1/125 sec., and so on.

- \* Simply turn Shutter Speed Dial (7) until the desired shutter speed is set opposite Shutter Speed Index Line (6) (Fig. 14).

Generally speaking, when shooting outdoors in bright or hazy sunlight, "125" (1/125 sec.) is suitable for most pictures. When taking your subjects in motion. "250" (1/250 sec.) to "500" (1/500 sec.) should be used. Faster speeds will "freeze" extremely fast moving subjects (sports, racing cars, etc.). When indoors in a well-lit room, "60" (1/60 sec.) should be sufficient to take your subjects, depending upon the film you are using. When in poorly-lit places, or to achieve the maximum depth of field, "30" (1/30 sec.) to "8" (1 sec.) are available. When set at "B" the shutter will remain open long as Shutter Release Button (9) is depressed (preferably by a cab release). The "B" setting is used for long night exposure using street lights or electric signs as a light source, or under poor lighting conditions when flash cannot be used.

### Tips for Better Results

- \* When using slow speeds (below 1/30 sec.) use a tripod or other firm support to prevent the movement of the camera and blurry pictures. In shooting with a telephoto lens, be careful to minimize the camera shake.
- \* Do not set Shutter Speed Dial (7) between marked speeds, but, click stop in accordance with indicated speeds only.
- \* Shutter Speed Dial (7) does not revolve between "500" and "B"

## SETTING APERTURE

The lens opening determines the amount of light entering the lens and exposing the film. The smaller the f-stop (f/2.2. f/2.8, etc.), the wider the lens opening and the greater the amount of light entering the lens. The larger the f-stop (f/16. f/11. etc.), the smaller the lens opening and the smaller the amount of light entering the lens.

As the lens opening is moved from f/16 to f/11, the amount of light entering the lens is doubled. As the lens opening is moved from f/2.8 to f/4 the amount of entering light is cut in half (Fig. 19).



Fig. 20

\* Rotate F-Stop Ring (18) until the desired f-stop is opposite the aperture index line (Fig.20)  
Click stop is provided to prevent accidental movement from the setting made.

### Tips for Better Results

- If necessary, you may set F-Stop Ring (18) between two f-stop

### VIEWING AND FOCUSING

Since you are viewing through the lens, there is no parallax problem. What you are viewing in the viewfinder will exactly appear in your picture. This enables you to determine the exact composition of your subjects before pressing Shutter Release Button (9). Even when you shoot close-ups, there is no danger of accidentally cutting off a portion of your picture. To assure the sharpest possible pictures, your KR-5 has a three way focusing screen with diagonal Split-image Spot (32). Microprism-image Band (31 ) and Fresnel field, and you can select three way focusing according to your subject.

1. Look into Viewfinder Eyepiece (21) to compose your subject.
2. Split-image Focusing, is helpful for the subject with either vertical or horizontal lines.



Out of focus  
Image brouillée  
Falsch  
Fuera de foco  
On-scherp  
Förstöras  
Fuori di fuoco

Rotate Focusing Ring (16) until the split image in Split-image Spot (32) forms a single image. When it is out of focus, your subject is split into two parts (Fig. 21).

3. Microprism-image Focusing, is good for the subject which lacks clear vertical or horizontal lines.---



Rotate Focusing Ring (16) until the image in Microprism-image Band (31) appears sharp (Fig. 21).

4. You can also focus with any part of the area surrounding Microprism-image Band (31) This is most useful when taking pictures with ultra telephoto lenses or in close-up photography with bellows unit, macro lenses or extension rings because the other focusing aids may darken appreciably.

## UNLOADING FILM

After the last picture on the roll of film has been taken, rewind the film and unload your camera.

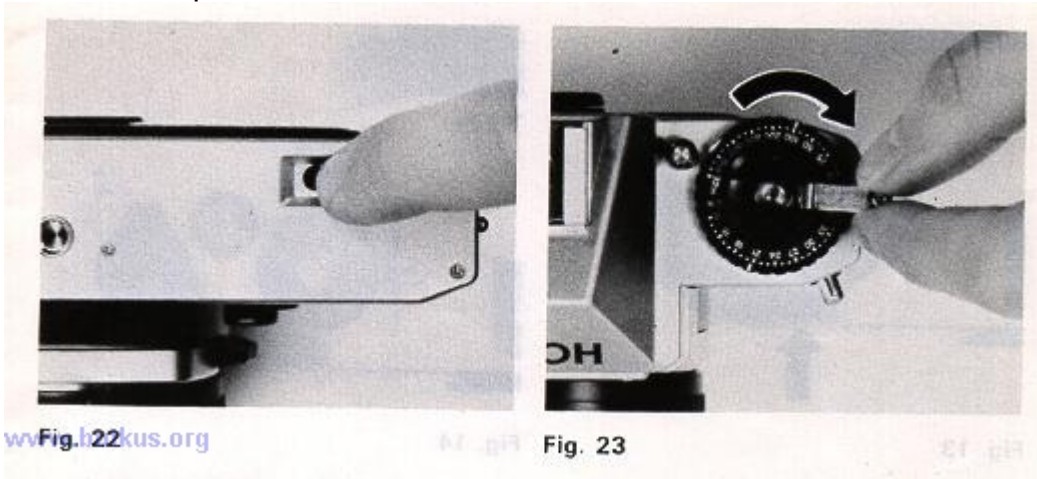

1. Press Film Rewind Release Button (27) (Fig. 22).

2. Lift up Film Rewind Crank (2) and turn it clockwise until Film Rewind Release Button (27) stops revolving and you feel the film tension released (Fig 23). This indicates that the film has been completely rewound into the cartridge.

3. Open Back Cover (29) by pulling up Film Rewind Knob (1)

4. Remove the film cartridge and have the film processed as soon as possible.

## Tips for Better Results

\* Always unload your camera in the shade or in a poorly-lit place never in direct sunlight or other bright light.

\* When you reach the end of the roll of film, Film Advance Level ( 11 ) will tighten and refuse to advance. If this happens, do not advance Film Advance Lever (11) by force for "Just one more shot", otherwise the film will be torn out of the cartridge.

\* Film Rewind Release Button (27) will remain in place once it is pressed, and return automatically to its original position when Film Advance Lever (11) is advanced.

## TAKING FLASH PICTURES

You can use a flash at night or in a dimly lit room as well as for supplementary lighting in outdoor photography. The camera and electronic flash will be fully synchronized with the shutter speed at "B" and 1/8 sec to 1/60 sec.

\* Mount a flash unit with a built-in hot shoe contact on Hot Shoe (5)

## Tips for Better Results

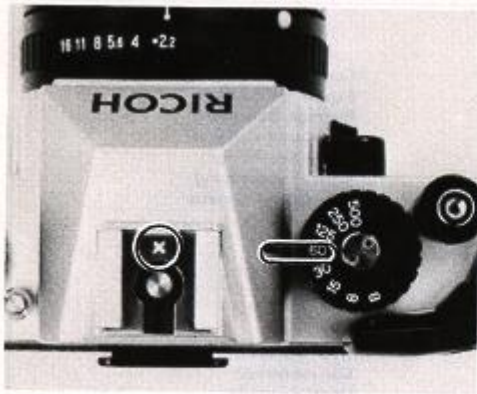

Fig. 24

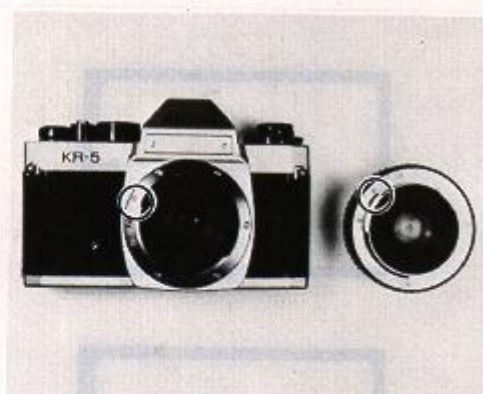

Fig. 25

\* Use a flash unit with a built-in hot shoe contact only because the camera is not equipped with flash terminal for a flash unit with connecting cord.

\* "60" (1/60 sec ) on Shutter Speed Dial (7) is marked in red as a reminder for electronic flash synchronization (Fig 24)

## Exposure for Flash Photography

The exposure is determined by the guide number of the electronic flash unit. The guide number represents a relationship between the light output of the flash and the speed of the film. Guide numbers for electronic flash units are found in the technical specifications. Using the guide number, you can determine the correct f-stop for a given flash situation using the following formula:

F-stop = Guide number - divided by - Flash-to-subject distance.

For example, if your flash unit has a guide number of 16(m) or 52.8 (ft.) for the type of film you are using, and your subject is 2 meters (6.6 ft ) from the flash unit as indicated on Distance Scale (17) after focusing, divide 16 (52.8) by 2 (6.6). The answer is 8. Therefore, set F-Stop Ring ( 18) to 8 (f/8).

(Mike: Most flash units have very good "A" auto modes. Find the F-stop the flash recommends and set the f-stop to that setting, as well as the shutter to 1/60. Newer Ricoh cameras can go to 1/125. Auto units with bounce will work automatically too.)

### Tips for Better Results

\* If you are using an auto electronic flash unit with power ratio control, follow the instruction sheets packed with the flash unit.

\* Most electronic flash units have a built-in dial or exposure table which enables you to quickly compute f-stops based on flash-to-subject distances.

## CHANGING LENSES

### To mount the lens on the camera

1. Mount the lens by lining up the red dot on the lens mount with the matching dot on the camera mount (Fig. 25).

2. Grasp the lens firmly around the lens barrel and turn it clockwise until it clicks into place.

### To remove the lens from the camera

1. Grasp the lens firmly around the lens barrel in one hand.

2. With the other hand, hold the camera body and press Lens Release Lever (14) and turn the lens counterclockwise until it stops (Fig. 26). The lens now can be removed.

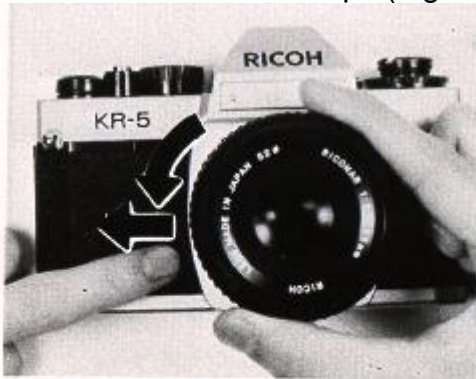

Fig. 26

You can also change lenses easily without looking even in the dark by means of Lens Locator Node (15). Line up Lens Locator Node (15) with Lens Release Lever (14) and turn the lens clockwise for mounting the lens. For removing the lens, press Lens Release Lever (14) and turn the lens counterclockwise until Lens Locator Node (15) and Lens Release Lever (14) line up.

## Tips for Better Results

- \* Whenever a lens is mounted on the camera, make sure that the lens is perfectly mounted.
- \* Do not touch any of the internal parts or permit dust or dirt to enter the camera body when removing or attaching lenses.
- \* Protect the inside of the camera by putting on the body cap whenever the camera is carried or kept with the lens removed....

## DEPTH OF FIELD

When you focus on a specific subject, an area in front of and behind the subject will appear acceptably sharp in your picture.

This area of acceptable sharpness is called "Depth of Field". The depth of field is determined by the f-stop you select and the distance from the in-focus subject to the film plane. As you get closer to your subject, or as you open your lens (for example from f/16 to f/2.2) the depth of field becomes shallower. By stopping the lens down (for example. from f/2.2 to f/16), the depth of field becomes deeper. The depth of field can be pre-determined in the following way.

## INTERCHANGEABLE LENSES AND ACCESSORIES

A wide range of XR RIKENON interchangeable lenses including, extremely wide angle lenses, telephoto lenses, zoom lenses and various accessories are available to enable you to expand the pleasure of your picture-taking. XR RIKENON interchangeable lenses and accessories are made of selected high quality materials under strict quality control to assure you of high performance and full satisfaction. Select XR RIKENON interchangeable lenses that will meet your needs.

**(MIKE: These can be the standard "K" mount lens, Ka (with Pentax "program" contact pins) or Kr (Ricoh "program" contact pins. Newer lenses are usually Ka/r that will work in program mode with Pentax and Ricoh cameras. It doesn't matter what lens as this is a fully manual camera)**

Since the camera is designed to accept any lens with the "K" type bayonet mount, your KR-5 affords you the opportunity to select any interchangeable lens or accessory of the "K" type bayonet mount available on the market.

## PROPER CARE OF YOUR CAMERA

- \* Always carry your camera with its carrying case and neck strap.
- \* Use the lens cap to protect the lens when not taking pictures.
- \* Protect your camera from dust, dirt, water, rain, dampness. salt air and rough handling....
- \* Never expose your camera to excessively high or low temperatures for an extended period of time. In extremely hot climates, do not leave your camera inside closed automobiles during the daytime or in direct sunlight.
- \* In extremely cold climates, expose your camera to the outer air only when in use. When using, expose your camera gradually to the outer air to prevent the lens from clouding.

\* If exposed to an extremely cold climates, the exposure meter batteries may fail to operate properly. Keep your camera inside your clothing until taking a picture.

\* Never touch the surfaces of the lens, metal focal plane shutter curtain, reflex mirror, etc. with your fingers.

\* To clean the lens, gently wipe it in a circular motion with a lens cleaning paper or a soft, clean and lintless cloth.

\* Do not wipe the camera body with chemicals, such as benzine, thinner, etc. use only soft cloth or cotton swab sprinkle LIGHTLY with alcohol on the camera body. Do not use them the lens because it can affect coating.

\* When your camera is not in use for an extended period of time put the lens cap, remove the batteries, place your camera in its carrying case together with silica gel or other desiccant and store it in a dry and cool place. \* Never store your camera in places where the temperatures are excessively high or low.

\* Do not attempt to disassemble or repair your camera yourself. If service is necessary, get in touch with your dealer or authorize Ricoh service station.

\* Do not leave your camera near the magnetic objects like radio television set, etc.

## **MAJOR SPECIFICATIONS OF KR-5**

**Camera Type:** 35 mm SLR with metal focal plane shutter.

**Film Format:** 24 x 36 mm

**Film Size and Capacity:** 35 mm perforated film in 12, 20, 24 or 36 exposures.

**Standard Lenses:** 55 mm RICONAR f/2.2. 4 groups 4 elements

**Filter size:** 52 mm screw-in type

**Lens Mount:** "K" type bayonet with 65° rotating angle

**Shutter:** Vertically moving Copal CCS metal focal plane shutter with speeds from 1/8 to 1/500 sec. plus B.

### **Viewfinder:**

Fixed eye-level pentaprism

Exposure meter needle and Shutter speed needle visible.

Viewing magnification 0.89X (55 mm f/2.2 lens)

Field of view covers 93% of actual picture area

**Focusing:** Diagonal Split-image spot in microprism-image band surrounded by Fresnel field



**Exposure Meter:** Two CdS photocells TTL full open metering for center-weighted average light reading coupled to shutter speeds, film speeds and f-stops.

**Exposure Coupling Range:** EV 5.3 - 17 (ASA 100 film with 55 mm f/2.2 lens)

**Film Speed Range:** ASA 12 ~ 3200 (DIN 12 ~ 36)

**Exposure Meter Power Supply:** Two 1.5V silver-oxide batteries (JIS G13, Mallory MS76 Eveready S76 or equivalent).

**Flash Synchronization:** X Synchronization for electronic flash unit at "B" and 1/8 sec. to 1/60 sec.

**Flash Contact:** "X" contact on hot shoe for cordless electronic flash unit

**Film Loading:** Multi-slit easy loading

**Film Wind:** Single stroke film advance lever with 135° winding angle (40° play)

**Film Rewind:** Film rewind crank by pressing film rewind button on base of camera

**Exposure Counter:** Additive, automatic resetting.

**Other Features:**

Hot shoe

Shutter release lock (with film advance lever)

Meter on/off switch (with film advance lever)

ASA/DIN dial lock

Cable release socket

Tripod socket

**Dimensions:** 139.9 (width) x 91.3 (height) x 48.0 (depth) mm (Body only)

**Weight:** 540 g (Body only)

\* Specifications are subject to change without notice.